

# Maintenance manual

## 95XF

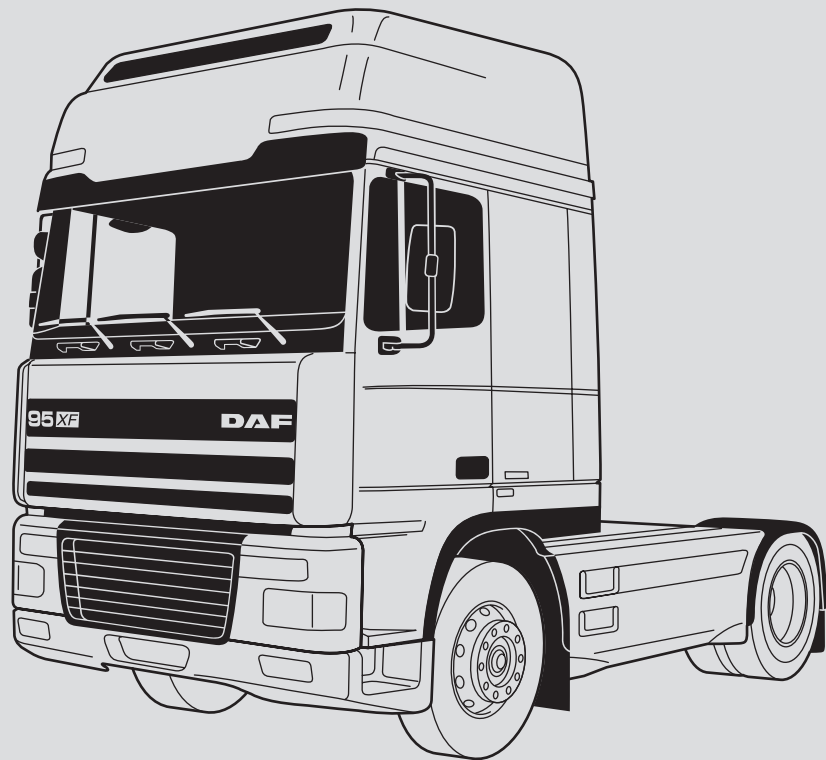



© 200424 DAF Trucks N.V., Eindhoven,  
the Netherlands

In the interest of continuing product  
development, DAF reserves the right to change  
specification or equipment at any time without  
notice.

No part of this publication may be reproduced  
and/or published by printing, photocopying,  
microfilming or by any other means without the  
manufacturer's prior permission in writing.



## STRUCTURE

---

**95XF** series

TECHNICAL DATA	<b>0</b>
	<b>1</b>
THREADED CONNECTIONS	<b>2</b>
FLUIDS, OIL AND LUBRICANTS	<b>3</b>
MAINTENANCE SCHEDULE	<b>4</b>
EXPLANATORY NOTES ON THE MAINTENANCE ACTIVITIES	<b>5</b>



**CONTENTS**

	<b>Page</b>	<b>Date</b>
<b>1. XF/XE ENGINE</b> .....	1-1 ....	200424
1.1 General .....	1-1 ....	200424
1.2 Tightening torques .....	1-2 ....	200424
1.3 Filling capacities .....	1-2 ....	200424
<b>2. VF ENGINE</b> .....	2-1 ....	200424
2.1 General .....	2-1 ....	200424
2.2 Tightening torques .....	2-2 ....	200424
2.3 Filling capacities .....	2-2 ....	200424
<b>3. GEARBOX</b> .....	3-1 ....	200424
3.1 Tightening torques .....	3-1 ....	200424
3.2 Filling capacities .....	3-2 ....	200424
<b>4. REAR AXLE</b> .....	4-1 ....	200424
4.1 General .....	4-1 ....	200424
4.2 Tightening torques .....	4-1 ....	200424
4.3 Filling capacities .....	4-1 ....	200424
<b>5. RETARDER</b> .....	5-1 ....	200424
5.1 Tightening torques .....	5-1 ....	200424
5.2 Filling capacities .....	5-1 ....	200424
<b>6. BRAKES</b> .....	6-1 ....	200424
6.1 General .....	6-1 ....	200424
<b>7. STEERING GEAR</b> .....	7-1 ....	200424
7.1 General .....	7-1 ....	200424
7.2 Tightening torques .....	7-1 ....	200424
<b>8. FRONT AXLE</b> .....	8-1 ....	200424
8.1 General .....	8-1 ....	200424
8.2 Tightening torques .....	8-1 ....	200424
<b>9. TRAILING AXLE</b> .....	9-1 ....	200424
9.1 General .....	9-1 ....	200424
9.2 Tightening torques .....	9-1 ....	200424
<b>10. LEADING REAR AXLE 09N044 (FTP-TYPE VEHICLES)</b> .....	10-1 ...	200424
10.1 General .....	10-1 ...	200424
10.2 Tightening torques .....	10-1 ...	200424

# TECHNICAL DATA

Contents

**95XF** series

**0**



**1. XF/XE ENGINE**

**1.1 GENERAL**

**Valve clearance**

Valve clearance (cold/warm):

inlet	0.45 mm
exhaust	0.45 mm

**DEB**

DEB setting	1.40 mm
-------------	---------

**V-belt tension**

Belt tension "12.5-mm" V-belts in Newtons (N)		
	Multiple V-belt	Single V-belt
	raw-edge <sup>1</sup>	raw-edge <sup>1</sup>
<b>New V-belt<sup>2</sup></b>		
Setting tension	1200	600
Test tension	≥ 800	≥ 400
<b>Worn-in V-belt<sup>3</sup></b>		
Minimum tension	500	250
Adjusting tension	700	350

- (1) Raw-edge V-belts can be recognised by looking at their edges and at the inside of the V-belt. Except for the upper part of the belt side, no textile fabric is present in the rubber (polished sides).  
Version: either a toothed or a non-toothed belt.
- (2) After fitting the new V-belt, set the pre-tension to the "setting tension" and after a trial run inspect whether the pre-tension complies with the "test tension". If the tension reading is lower than the "test tension" specified in the table, set the V-belt to the minimum "test tension".
- (3) If the V-belt tension is lower than the "minimum tension", set the belt to the "adjusting tension".

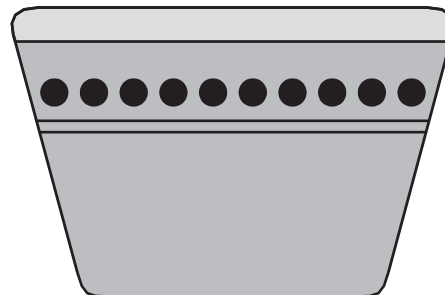

M2121



## TECHNICAL DATA

XF/XE engine

**95XF** series

### 1.2 TIGHTENING TORQUES

0

#### Lubrication system

Oil drain plug	60 Nm
Oil filter	45 Nm
Central bolt for centrifugal oil filter	20 Nm

#### Valve cover

Valve cover attachment bolts	25 Nm
------------------------------	-------

#### DEB

DEB attachment bolts	110 Nm
DEB set screw nut	25 Nm

### 1.3 FILLING CAPACITIES

Oil sump (incl. engine oil filter)	approx. 29 litres
Cooling system with integrated ZF retarder	approx. 50 litres + 10 litres

**2. VF ENGINE**

**2.1 GENERAL**

**0**

**Valve clearance**

(cold)

Inlet valve	0.35 mm
Exhaust valve	0.70 mm

**Unit injector**

Setting value for unit injector (cold)	0.50 - 0.75 mm
--	----------------

**C-brake**

Setting value for C-brake (cold)	0.58 mm
----------------------------------	---------

**V-belt tension**

<b>Belt tension for poly V-belts in Newtons (N)</b>		
	6-rib version	10-rib version
<b>New poly V-belt</b>	700	1100
<b>Run-in poly V-belt<sup>1</sup></b>	300 - 600	450 - 900

(1) A run-in poly V-belt is a belt which has been used for 10 minutes or longer.

If the belt tension of a run-in poly V-belt is below the minimum permitted tension, it should be adjusted to the maximum permitted tension.

## TECHNICAL DATA

VF engine

95XF series

### 2.2 TIGHTENING TORQUES

0

#### Lubrication system

Oil drain plug	135 Nm
Oil filter	55 Nm

#### Valve cover

Valve cover attachment bolts	12 Nm
Lock nut for valve clearance adjusting bolt	55 Nm

#### Unit injector

Lock nut for unit injector adjusting bolt	65 Nm
Unit injector attachment bolt	40 Nm

#### C-brake

Lock nut for C-brake adjusting bolt	24 Nm
C-brake housing attachment bolts	102 Nm

#### Rocker housing

Rocker housing attachment bolts (1 to 6)	115 Nm
Rocker housing attachment bolts (7-8)	45 Nm

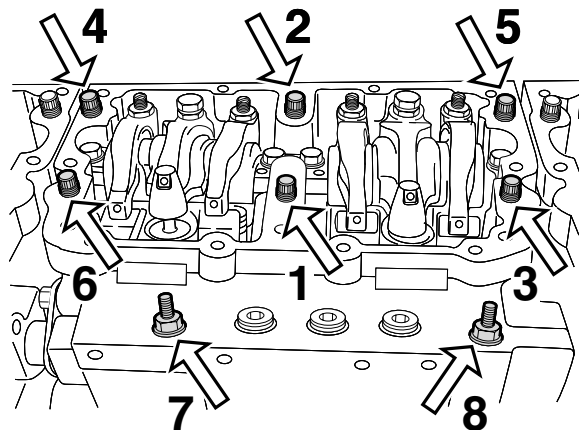

M2144

#### Rocker shaft

Rocker shaft attachment bolts	156 Nm
-------------------------------	--------

### 2.3 FILLING CAPACITIES

Oil sump (incl. engine oil filter)	approx. 42 litres
Cooling system	approx. 37 litres

### 3. GEARBOX

#### 3.1 TIGHTENING TORQUES

**Gearbox**

**ZF 8S-151/181 and 16S-151/181/221**

Level check/filler plug (A)	60 Nm
Drain plug (B)	60 Nm
Drain plug (C/D)	60 Nm

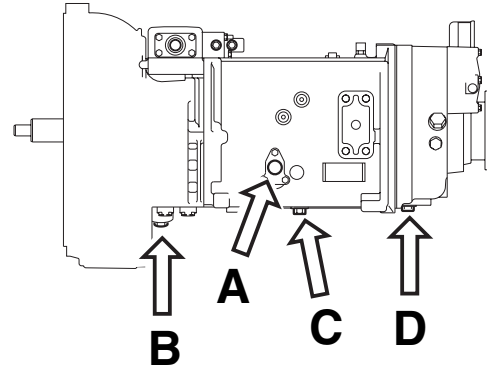

M3023

**ZF 8S-151/181 and 16S-151/181/221**

**with integrated retarder**

Drain plug (D)	60 Nm
Oil filter attachment bolt (1)	23 Nm

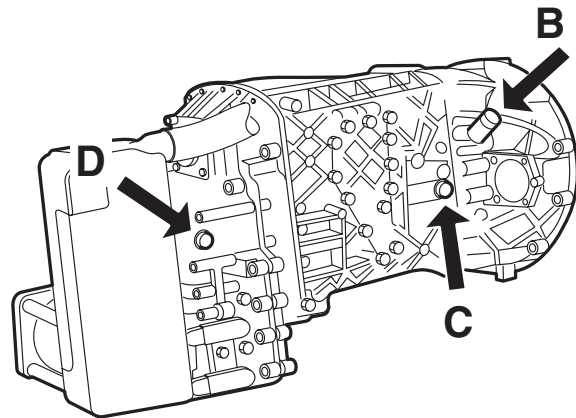

V300186

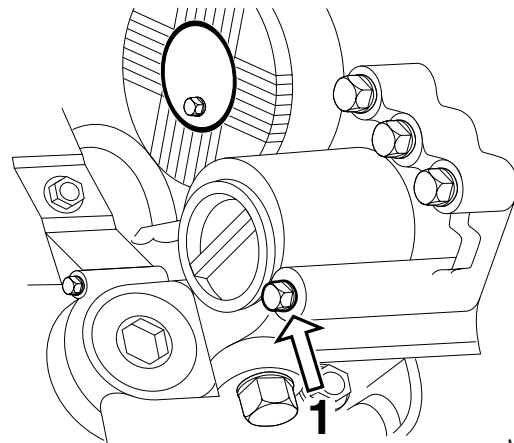

M3052



## TECHNICAL DATA

---

Gearbox

**95XF** series

### 3.2 FILLING CAPACITIES

0

**ZF 16S-181**

Filling capacity

approx. 13 litres

**ZF 16S-221**

Filling capacity

approx. 13 litres

**ZF 16S-181/221 with integrated retarder**

Filling capacity

approx. 12 litres

**4. REAR AXLE**

**4.1 GENERAL**

Wheel bearing play, 1347 axle 0.025 - 0.25 mm

**4.2 TIGHTENING TORQUES**

Filler and drain plugs/hub plugs (Torx wrench)	85 Nm
M24 hexagon U-bolt nut, property class 8	600 Nm*
M24 hexagon U-bolt nut, property class 10	770 Nm*
M22 hexagon U-bolt nut (tandem axle), property class 10	555 Nm*

\* Evenly tighten the two U-bolt nuts alternately.

**4.3 FILLING CAPACITIES**

**Differential**

**1347 axle**

Filling capacity	Minimum caster approx. 21.5 litres	Maximum caster approx. 23.5 litres
------------------	---------------------------------------	---------------------------------------

**1354 axle**

Filling capacity approx. 16.5 litres

**1355T axle**

1st axle capacity	Minimum caster approx. 13.0 litres	Maximum caster approx. 18.0 litres
2nd axle capacity	approx. 11.5 litres	approx. 13.0 litres

**Wheel hub**

**1347 axle**

Filling capacity per hub approx. 0.9 litres

**1354 axle**

Filling capacity per hub approx. 2 litres

**1355T axle**

Filling capacity per hub approx. 2 litres



## TECHNICAL DATA

Rear axle

**95XF** series

**0**



## 5. RETARDER

### 5.1 TIGHTENING TORQUES

#### VOITH retarder 133-2

Retarder drain plug	150 Nm
Butterfly valve drain plug	65 Nm
Retarder dipstick	80 Nm
Retarder level check plug	80 Nm
Retarder filler plug M18 x 1.5	50 Nm
M24 x 1.5	80 Nm
Coolant drain plug	50 Nm

### 5.2 FILLING CAPACITIES

Voith 133-2	
Filling capacity	8.2 litres

0

## TECHNICAL DATA

---

Retarder

**95XF** series

**0**

## **6. BRAKES**

### **6.1 GENERAL**

Automatic brake adjuster stroke (09N044 axle, FTP-type vehicles)	25 - 35 mm
Automatic brake adjuster stroke (other axles)	35 - 40 mm
Reverse torque of adjusting bolt	> 18 Nm

## TECHNICAL DATA

---

Brakes

**95XF** series

**0**

**95XF** series

Steering gear

## **7. STEERING GEAR**

### **7.1 GENERAL**

Maximum steering ball joint axial clearance 1.5 mm

### **7.2 TIGHTENING TORQUES**

Retention bolt/nut for universal joint steering box input shaft 30 Nm + 60° angular displacement\*

\* Always replace bolt and nut

**0**

## TECHNICAL DATA

Steering gear

**95XF** series

**0**

**95XF** series

Front axle

## **8. FRONT AXLE**

### **8.1 GENERAL**

Wheel bearing play 0.025 - 0.25 mm

### **8.2 TIGHTENING TORQUES**

Wheel hub lock nut	210 ± 30 Nm
Hub cap bolt	9 Nm
Wheel nut (steel/aluminium)	700 Nm
	Tighten after 100 km
M22 hexagon U-bolt nut, property class 8	480 Nm*

\* Evenly tighten the two U-bolt nuts alternately.

**0**

## TECHNICAL DATA

Front axle

**95XF** series

**0**



**95XF** series

Trailing axle

## 9. TRAILING AXLE

### 9.1 GENERAL

Wheel bearing play	0.025 - 0.25 mm
Hub cap sealant	Silicone sealant

### 9.2 TIGHTENING TORQUES

Wheel hub lock nut, 09N220 axle	560 Nm
Wheel hub lock nut, 09N075 axle	210 ± 30 Nm
Hub cap bolts, 09N220 axle	70 Nm
Wheel nut (steel/aluminium)	700 Nm
	Tighten after 100 km

0

## TECHNICAL DATA

---

Trailing axle

**95XF** series

**0**

**95XF** series

Leading rear axle 09N044 (FTP-type vehicles)

**10. LEADING REAR AXLE 09N044 (FTP-TYPE VEHICLES)**

**10.1 GENERAL**

Wheel bearing play 0 mm

**10.2 TIGHTENING TORQUES**

The tightening torques stated in this paragraph are different from the standard tightening torques stated in the overview of standard tightening torques. Any other threaded connections that are not specified must therefore be tightened to the tightening torque stated in the overview of standard tightening torques.

When attachment bolts and nuts are to be replaced, it is important that they are of exactly the same length and property class as the ones removed, unless stated otherwise.

Hub nut	100 Nm <sup>(1)</sup>
Hub cap	500 Nm
U-bolt nut M20, property class 10	553 Nm <sup>(2)</sup>

<sup>(1)</sup> Turn back until split pin can be fitted.  
<sup>(2)</sup> Evenly tighten the two U-bolt nuts alternately.

## TECHNICAL DATA

Leading rear axle 09N044 (FTP-type vehicles)

**95XF** series

**0**

# THREADED CONNECTIONS

95XF series

Contents

## CONTENTS

	Page	Date
1. THREADED CONNECTIONS .....	1-1 .....	200424
1.1 General .....	1-1 .....	200424

# THREADED CONNECTIONS

---

Contents

**95XF** series

**2**

## **1. THREADED CONNECTIONS**

### **1.1 GENERAL**

The vehicle components are provided with threaded connections, which have been treated with lubricant (dipped threaded connection). Factory-galvanised bolts and nuts are wax-dipped. Black annealed and phosphatised bolts and nuts are oil-dipped. The advantage of using dipped nuts and bolts is that friction during tightening is reduced, so that the specified pre-tension force can be accurately obtained. The tightening torque can be reduced while the pre-tension force remains the same.

To achieve a small spread in the pre-tension force, the dipped threaded connection must be tightened accurately. Therefore, always use a reliable and accurate torque wrench.

**Note:**

Have torque wrenches regularly inspected and calibrated.

To achieve the correct pre-tension when re-using threaded connections, it is important to clean the threaded parts thoroughly. After cleaning, apply one drop of lubricant to the first turn of the screw thread and one drop to the abutting surface of the nut or bolt. If bolts and nuts to be re-used, do not lubricate them with anything other than engine oil. Lubricants other than engine oil or factory-applied lubricant must not be used under any circumstances because of the difference in frictional coefficient.

If a locking compound was specified, no oil should be applied to the thread.

## THREADED CONNECTIONS

Threaded connections

95XF series

2

**The following applies to all threaded connections (for both new and used vehicles):**

- in the case of standard connections, apply the lubricant before fitting, and retighten in accordance with the standard for dipped bolts;
- in the case of special connections, apply the lubricant before fitting, and retighten in accordance with the values specified in the instructions.

The instructions for using a lubricant also apply to new bolts supplied from the warehouse. Dry threaded connections are not permitted because of their highly variable friction coefficients.



**Please consult the workshop manual for the specified tightening torque.**



# COOLANT, OIL AND LUBRICANTS

95XF series

Contents

## CONTENTS

	Page	Date
1. SPECIFICATIONS .....	1-1	200424
1.1 General .....	1-1	200424

## COOLANT, OIL AND LUBRICANTS

---

Contents

**95XF** series

**3**

## **1. SPECIFICATIONS**

### **1.1 GENERAL**

**IN ORDER TO SATISFY THE WARRANTY CONDITIONS AND GUARANTEE THE LIFESPAN, SAFETY AND RELIABILITY OF DAF PRODUCTS, IT IS OF THE UTMOST IMPORTANCE THAT THE CORRECT FLUIDS, OIL AND LUBRICANTS, COOLANT AND FUEL ARE USED, AND THAT THE REQUIRED REPLACEMENT INTERVALS ARE OBSERVED.**

Additives to lubricants, engine coolant and fuel - of whatever type - must not be used except in those circumstances prescribed by DAF.

Always follow the safety instructions below as well as the instructions that are supplied with the product.

Ask your lubricant and fuel supplier(s) whether the products supplied comply with DAF specifications.



**DAF is not liable for damage or problems in the following instances: :**

- 1. If oil of a quality inferior to that specified is used.**
- 2. If oil of a different viscosity than specified is used.**
- 3. If the replacement interval is exceeded.**
- 4. If fuel, lubricants or coolants that do not meet the requirements specified by DAF are used.**

## COOLANT, OIL AND LUBRICANTS

### Specifications

95XF series

**Avoid contact with:**

- Lubricants
- Coolant
- Fuel
- Clutch fluid

**In the event of contact with the skin: remove with paper or a cloth, wash with soap and water. If irritation persists, consult a doctor.**

**In the event of contact with the eyes: remove with a cloth and rinse with water. If irritation persists, consult a doctor.**

**If any is swallowed: DO NOT induce vomiting. Rinse mouth, drink two glasses of water and consult a doctor.**

**In the event of inhalation: Get some fresh air and rest.**

**Note:**

Refer to the "Fluids and lubricants" specification manual for the prescribed fluid, oil and lubrication specifications.

3

# MAINTENANCE SCHEDULE

95XF series

Contents

## CONTENTS

	Page	Date
<b>1. MAINTENANCE INTERVALS</b> .....	1-1	200424
1.1 Maintenance schedule .....	1-1	200424
1.2 Explanatory notes on the maintenance schedule .....	1-2	200424
1.3 Influence of diesel fuel and PTO hours on maintenance intervals .....	1-4	200424
1.4 Maintenance intervals under special operating conditions .....	1-4	200424
1.5 First service inspection .....	1-4	200424
<b>2. MAINTENANCE</b> .....	2-1	200424
2.1 Overview of maintenance activities for the first service inspection .....	2-1	200424
2.2 Overview of annual maintenance activities .....	2-2	200424
2.3 Overview of mileage-dependent maintenance activities .....	2-4	200424
2.4 Overview of intermediate inspection activities .....	2-6	200424

# MAINTENANCE SCHEDULE

Contents

**95XF** series

**4**

# MAINTENANCE SCHEDULE









95XF series

Maintenance intervals

## 1. MAINTENANCE INTERVALS

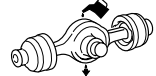
### 1.1 MAINTENANCE SCHEDULE

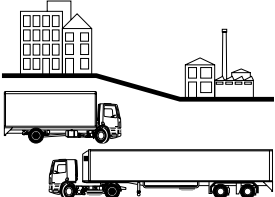
The service intervals stated in the maintenance schedule are based on use of the oils and fuels specified by DAF.

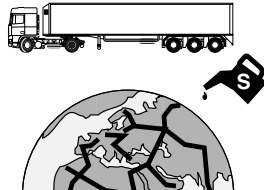
Maintenance schedule		Intermediate inspection	X service	Y service 1x per YEAR	
45 55 65CF 75CF 85CF 95XF			 +	 +	
				 (1)	
I			15.000 km	1 year max.100.000 km	1 year max.100.000 km
II			30.000 km	1 year max.100.000 km	1 year max.100.000 km
III			50.000 km (2)	1 year max.100.000 km	1 year max.200.000 km (3)
		50.000 km (4)	100.000 km (4)	2 year max.300.000 km (5)	2 year max.300.000 km (6)

G000085

- (1) 1 year/max. 40,000 km for automatic gearboxes.
- (2) For 65CF, 40,000 km.  
For 45/55 series, 30,000 km.
- (3) 1 year/max. 100,000 km, if the 1347 axle is not used.
- (4) Applicable with the extended changing interval (100,000 km), if permitted, see "Explanatory notes on the maintenance schedule" in the maintenance manual.
- (5) Only applicable to ZF gearboxes.
- (6) 2 year/max. 200,000 km, if the 1347 axle is not used.

# MAINTENANCE SCHEDULE

Maintenance intervals

95XF series

## 1.2 EXPLANATORY NOTES ON THE MAINTENANCE SCHEDULE

### MAINTENANCE GROUP CLASSIFICATION

Depending upon the use to which the vehicle is put, the vehicle is placed in maintenance group I, II or III.

#### Maintenance group I

Operation on building sites, in quarries, etc.

- Operation on unmetalled roads
- Operation in dusty environments
- Sanitation department vehicles
- Distribution transport with an annual mileage up to 30,000 km.

#### Maintenance group II

Urban and regional transport

- Distribution transport in cities
- Traffic between adjacent villages/cities

#### Maintenance group III

(Inter)national traffic

- Long-distance/very long-distance transport

### STANDARD CHANGING INTERVAL

This is the symbol for the standard changing interval. See "Fluids and lubricants" specifications manual for prescribed oil specification.

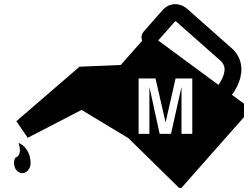

G000089

### EXTENDED CHANGING INTERVAL

This is the extended changing interval symbol.

If the prescribed oil specification and any additional conditions (see specification manual "Fluids and lubricants") have to be complied with, an extended changing interval may be applied.

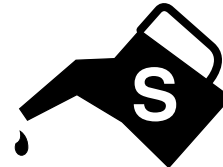

G000077

#### Note:

An extended engine oil changing interval is not allowed for the VF and XE engines.



# MAINTENANCE SCHEDULE

95XF series

Maintenance intervals

## INTERMEDIATE INSPECTION

This is the intermediate inspection symbol. Intermediate inspections are based on several visual inspections.

When an extended changing interval is applicable to the engine oil (X-service) an intermediate inspection should be carried out.

## Intermediate inspection



G000088

## X-SERVICE INTERVAL

This is the symbol of the X-service. An X-service is a maintenance check depending upon the distance covered which consists of changing the engine oil plus a number of visual inspections.

### Note:

An X-service must be carried out at least once a year.

## X service



+

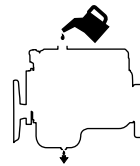

G000086

## Y-SERVICE INTERVAL

This is the symbol of the Y-service. A Y-service is an annual maintenance check consisting of several maintenance activities plus changing of the gearbox and rear axle oil.

## Y service

1x per YEAR



+

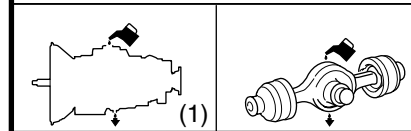

G000087

## MAINTENANCE SCHEDULE

Maintenance intervals

95XF series

### 1.3 INFLUENCE OF DIESEL FUEL AND PTO HOURS ON MAINTENANCE INTERVALS

#### Diesel fuels

Sulphur content	Engine oil changing interval
> 0.2%	Halve interval to max. of 25,000 km

#### PTO hours

PTO hours should be converted into mileage according to the following formula:

1 PTO hour of XF engine = 20 km

1 PTO hour of XE engine = 40 km

### 1.4 MAINTENANCE INTERVALS UNDER SPECIAL OPERATING CONDITIONS

4

Contact a DAF dealer/main branch or importer for vehicles used in very specific or heavy conditions.

The service intervals can be adapted, if necessary, in consultation with the dealer/main branch or importer to fit the appropriate operating conditions.

### 1.5 FIRST SERVICE INSPECTION

The first service inspection should be carried out between the first 7,500 and 10,000 km or at most 8 weeks after delivery of the vehicle, whichever comes first.

#### Note:

- For the 1355T, the oil must be changed between the first 2,000 and 3,000 km.

## **2. MAINTENANCE**

### **2.1 OVERVIEW OF MAINTENANCE ACTIVITIES FOR THE FIRST SERVICE INSPECTION**

- Change engine oil
- Change oil filter
- Change gearbox oil/transfer gearbox oil
- Change retarder oil (Voith retarder)
- Change differential oil
- Change hub oil
- Check components and hose connections for leaks
- Check/adjust load-dependent control valve, leaf suspension
- Check U-bolt attachment
- Retighten hub nut of leading rear axle 09N044 (FTP-type vehicles)

# MAINTENANCE SCHEDULE

Maintenance activities

95XF series

## 2.2 OVERVIEW OF ANNUAL MAINTENANCE ACTIVITIES

### ANNUAL MAINTENANCE ACTIVITIES (Y-SERVICE)

"Correct if necessary after inspection"

#### CAB AND ELECTRICAL SYSTEM

- Check pedal rubbers
- Check headlight setting
- Check fluid level of cab tilting pump
- Check cab fastening

#### ENGINE, COOLING SYSTEM AND FUEL SYSTEM

- Replace air filter element
- Check/adjust valve clearance- **See Note 6** Done  Yes  No
- Check/adjust valve clearance and unit injectors (VF engine)
- Check/adjust C-brake clearance (VF engine)
- Check/adjust DEB clearance
- Clean fuel coarse filter (XE engine)
- Replace coolant filter
- Check antifreeze content of coolant
- Change coolant - **See Note 1** Changed  Yes  No
- Check glow plugs - **See Note 7**

#### STEERING GEAR AND BRAKE SYSTEM

- Replace steering gear filter element - **See Note 8** Replaced  Yes  No
- Check steering ball joints
- Replace air dryer filter element
- Check compressor line
- Check brake cylinder fastening
- Check automatic brake adjuster
- Check/adjust load-dependent control valve
- Check electropneumatic valves of ABS/ASR
- Check attachment of universal joint of steering box input shaft
- Push front axle wheel speed sensors up against pole ring

#### DRIVE AND CHASSIS

- Check fluid level of trailing axle lifting device
- Check pivot points of trailing axle lifting device
- Change differential oil - **See Note 2** Changed  Yes  No
- Change hub oil - **See Note 2** Changed  Yes  No
- Check operation of differential lock
- Check drive shaft play
- Change gearbox oil - **See Note 3** Changed  Yes  No
- Change retarder oil (Voith retarder) - **See Note 5** Changed  Yes  No
- Replace grease of grease lubricated hubs - **See Note 4** Replaced  Yes  No
- Check fifth wheel
- Check trailer coupling
- Check superstructure attachment

#### OTHER ACTIVITIES

- Check whether there are any field actions that need to be performed on the vehicle.

## MAINTENANCE SCHEDULE

### 95XF series

### Maintenance activities

**Note:**

- (1) Every 2 years with coolant according to DAF specification 74001.  
Every 4 years with coolant according to DAF specification 74002.
- (2) For changing interval, see maintenance schedule in maintenance manual.
- (3) For changing interval, see maintenance schedule in maintenance manual.  
When changing the gearbox oil on a gearbox with interarder or an automatic gearbox, the gearbox oil filter must also be replaced.
- (4) Every two years if yearly mileage >150,000 km.  
Every three years if yearly mileage ≤150,000 km.  
Every three years, at a maximum of 500,000 km with FTP vehicle leading rear axle.
- (5) When using mineral oil: Change oil after every 100,000 km, or every year, whichever comes first.  
When using synthetic oil: Change oil after every 150,000 km, or every year, whichever comes first.
- (6) Check the valve clearance every 2 years after the 2nd Y-service and adjust if necessary (example: 1st - 2nd - 4th - 6th... year).
- (7) Once every 2 years at a maximum of 250,000 km.
- (8) Every 2 years.

# MAINTENANCE SCHEDULE

Maintenance activities

95XF series

## 2.3 OVERVIEW OF MILEAGE-DEPENDENT MAINTENANCE ACTIVITIES

### MILEAGE-DEPENDENT MAINTENANCE ACTIVITIES (X-SERVICE)

"Correct if necessary after inspection"

#### CAB AND ELECTRICAL SYSTEM

- Clean/renew heater ventilation filter Replaced  Yes  No
- Clean battery terminals
- Check/top up battery fluid level

#### ENGINE, COOLING SYSTEM AND FUEL SYSTEM

- Change engine oil
- Replace oil filter
- Change rotor of centrifugal oil filter
- Clean air filter element
- Replace fuel filter
- Replace Racor filter element
- Check for fuel leaks
- Check/adjust V-belt Replaced  Yes  No
- Check components and hose connections for leaks
- Check radiator and intercooler for fouling
- Check air inlet system hoses and seals
- Check exhaust system

#### STEERING GEAR AND BRAKE SYSTEM

- Check steering ball joint sleeve for damage
- Check steering oil level
- Check steering gear pipes and connections
- Check brake components/brake system for leaks
- Check brake lining thickness

#### DRIVE AND CHASSIS

- Check clutch fluid level
- Check HGS fluid level
- Check central axle of tandem axle unit for leaks
- Check wheel bearing play of leading rear axle 09N044 (FTP-type vehicles)
- Check differential for leaks - **See Note 1**
- Check oil and grease lubricated hubs for leaks - **See Note 1**
- Check gearbox for leaks - **See Note 2**
- Check Voith retarder for leaks - **See Note 3**
- Check attachment of shock absorbers and check for leaks
- Check condition and attachment of spring leaves, spring clamps and U-bolts
- Check pivots of axle suspension, air suspension
- Check air suspension bellows
- Check grease supply of automatic lubrication system
- Check operation of automatic lubrication system
- Lubricate according to lubrication schedule

#### OTHER ACTIVITIES

- Check whether there are any field actions that need to be performed on the vehicle.

## MAINTENANCE SCHEDULE

### 95XF series

### Maintenance activities

**Note:**

- (1) For changing interval, see maintenance schedule in maintenance manual.
- (2) For changing interval, see maintenance schedule in maintenance manual.  
When changing the gearbox oil on a gearbox with interarder or an automatic gearbox, the gearbox oil filter must also be replaced.
- (3) When using mineral oil: Change oil after every 100,000 km, or every year, whichever comes first.  
When using synthetic oil: Change oil after every 150,000 km, or every year, whichever comes first.

# MAINTENANCE SCHEDULE

Maintenance activities

95XF series

## 2.4 OVERVIEW OF INTERMEDIATE INSPECTION ACTIVITIES

### INTERMEDIATE INSPECTION ACTIVITIES

**"Correct if necessary after inspection"**

In case of 100,000 km service intervals, an intermediate inspection should take place between the X-service intervals.

#### CAB AND ELECTRICAL SYSTEM

- Clean/renew heater ventilation filter Replaced  Yes  No

#### ENGINE, COOLING SYSTEM AND FUEL SYSTEM

- Check engine oil level
- Clean air filter element
- Check for fuel leaks
- Check/adjust V-belt Replaced  Yes  No
- Check components and hose connections for leaks
- Check radiator and intercooler for fouling
- Check air inlet system hoses and seals
- Check exhaust system
- Check Racor filter for water separation

#### STEERING GEAR AND BRAKE SYSTEM

- Check steering ball joint sleeve for damage
- Check steering oil level
- Check steering gear pipes and connections
- Check brake components/brake system for leaks
- Check brake lining thickness

#### DRIVE AND CHASSIS

- Check clutch fluid level
- Check HGS fluid level
- Check differential for leaks
- Check oil and grease lubricated hubs for leaks
- Check central axle of tandem axle unit for leaks
- Check gearbox for leaks
- Check Voith retarder for leaks
- Check attachment of shock absorbers and check for leaks
- Check condition and attachment of spring leaves, spring clamps and U-bolts
- Check pivots of axle suspension, air suspension
- Check air suspension bellows
- Check grease supply of automatic lubrication system
- Check operation of automatic lubrication system
- Lubricate according to lubrication schedule

#### OTHER ACTIVITIES

- Check whether there are any field actions that need to be performed on the vehicle.



# EXPLANATORY NOTES ON THE MAINTENANCE ACTIVITIES

95XF series

Contents

## CONTENTS

	Page	Date
<b>1. SAFETY INSTRUCTIONS</b> .....	1-1	200424
<b>2. GENERAL</b> .....	2-1	200424
2.1 Introduction .....	2-1	200424
2.2 Technical information .....	2-1	200424
2.3 Warning symbol .....	2-2	200424
2.4 Environment .....	2-2	200424
2.5 Parts .....	2-3	200424
2.6 Maintenance guidelines .....	2-4	200424
<b>3. INSPECTION AND ADJUSTMENT</b> .....	3-1	200424
<b>Cab and electrical system</b>		
3.1 Checking the pedal rubbers .....	3-1	200424
3.2 Checking the battery fluid level .....	3-2	200424
3.3 Checking the battery terminals .....	3-2	200424
3.4 Inspection and adjustment, headlight setting .....	3-3	200424
3.5 Checking the fluid level of the cab tilting pump .....	3-4	200424
3.6 Checking the cab fastening .....	3-4	200424
<b>Engine, cooling system and fuel system</b>		
3.7 Inspection and adjustment, valve clearance .....	3-5	200424
3.8 Inspection and adjustment, DEB clearance .....	3-7	200424
3.9 Inspection and adjustment, valve clearance and unit injectors .....	3-8	200424
3.10 Inspection and adjustment, C-brake play .....	3-13	200424
3.11 Inspection and adjustment, V-belt tension .....	3-16	200424
3.12 Checking the antifreeze content in the cooling system .....	3-21	200424
3.13 Checking the Racor filter element for water separation .....	3-22	200424
3.14 Checking the exhaust system .....	3-22	200424
3.15 Bleeding the fuel system .....	3-23	200424
3.16 Checking the glow coils .....	3-25	200424
<b>Steering gear and brake system</b>		
3.17 Checking the radiator and intercooler for fouling .....	3-26	200424
3.18 Checking the steering oil level .....	3-26	200424
3.19 Checking the steering gear pipes and connections .....	3-27	200424
3.20 Checking the steering ball joints .....	3-28	200424
3.21 Checking the brake components/brake system for leaks .....	3-29	200424
3.22 Checking the brake lining thickness .....	3-30	200424
3.23 Checking the brake cylinder fastening .....	3-31	200424
3.24 Checking the automatic brake adjuster .....	3-32	200424
3.25 Inspection and adjustment, load-dependent control valve, leaf suspension .....	3-33	200424
3.26 Inspection and adjustment, load-dependent control valve, air suspension .....	3-35	200424
3.27 Checking the electropneumatic valves of ABS/ASR .....	3-37	200424
3.28 Checking the compressor line .....	3-38	200424
3.29 Checking the attachment of the universal joint of the steering box input shaft .....	3-40	200424

# EXPLANATORY NOTES ON THE MAINTENANCE ACTIVITIES

## Contents

95XF series

	Page	Date
<b>Drive and chassis</b>		
3.30	Checking the clutch fluid level .....	3-41 ... 200424
3.31	Checking the HGS fluid level .....	3-42 ... 200424
3.32	Checking the oil and grease lubricated hubs for leaks .....	3-43 ... 200424
3.33	Checking the differential for leaks .....	3-43 ... 200424
3.34	Checking the gearbox for leaks .....	3-43 ... 200424
3.35	Checking the retarder for leaks .....	3-43 ... 200424
3.36	Checking the oil level of the central axle of the tandem unit .....	3-43 ... 200424
3.37	Checking the operation of the differential lock .....	3-44 ... 200424
3.38	Checking the fluid level in the hydraulic lifting gear .....	3-44 ... 200424
3.39	Checking the pivots of the axle suspension, air suspension .....	3-45 ... 200424
3.40	Checkign the drive shaft play .....	3-46 ... 200424
3.41	Checking the air suspension bellows .....	3-47 ... 200424
3.42	Checking the operation of the automatic lubrication system .....	3-47 ... 200424
3.43	Checking the fifth wheel .....	3-48 ... 200424
3.44	Checking the trailer coupling .....	3-49 ... 200424
3.45	Retightening the hub nut of leading rear axle 09N044 (FTP-type vehicles) .....	3-50 ... 200424
3.46	Inspection and adjustment, wheel bearing play .....	3-51 ... 200424
3.47	Checking the wheel hub and wheel bearings .....	3-60 ... 200424
3.48	Checking the superstructure attachment .....	3-60 ... 200424
3.49	Checking the attachment and condition of spring leaves, spring clamps and U-bolts .....	3-60 ... 200424
<b>4.</b>	<b>REMOVAL AND INSTALLATION .....</b>	<b>4-1 .... 200424</b>
<b>Cab and electrical system</b>		
4.1	Removal and installation, interior filter element .....	4-1 .... 200424
<b>Engine, cooling system and fuel system</b>		
4.2	Removal and installation, oil filter .....	4-2 .... 200424
4.3	Removal and installation, centrifugal oil filter rotor .....	4-4 .... 200424
4.4	Removal and installation, air filter element .....	4-5 .... 200424
4.5	Removal and installation, fuel filter .....	4-6 .... 200424
4.6	Removal and installation, Racor-filter element .....	4-8 .... 200424
4.7	Removal and installation, fuel coarse filter .....	4-9 .... 200424
4.8	Removal and installation, coolant filter .....	4-10 ... 200424
4.9	Removal and installation, V-belt .....	4-12 ... 200424
4.10	Removal and installation, C-brake .....	4-16 ... 200424
4.11	Removal and installation, valve cover .....	4-17 ... 200424
4.12	Removal and installation, DEB .....	4-19 ... 200424
<b>Steering gear and brake system</b>		
4.13	Removal and installation, steering gear filter element .....	4-20 ... 200424
4.14	Removal and installation, air dryer filter element .....	4-21 ... 200424
<b>Drive and chassis</b>		
4.15	Removal and installation, gearbox oil filter .....	4-22 ... 200424
4.16	Removal and installation, wheel hub .....	4-24 ... 200424
4.17	Removal and installation, hub oil seal .....	4-33 ... 200424
4.18	Removal and installation, hub oil seal/wheel speed sensor ring unit .....	4-37 ... 200424

## EXPLANATORY NOTES ON THE MAINTENANCE ACTIVITIES

95XF series

Contents

	Page	Date
<b>5. DRAINING AND FILLING</b> .....	5-1	200424
<b>Engine, cooling system and fuel system</b>		
5.1 Topping up battery fluid .....	5-1	200424
5.2 Draining and filling, engine oil .....	5-2	200424
5.3 Draining and filling/bleeding, cooling system .....	5-3	200424
<b>Drive and chassis</b>		
5.4 Draining and filling, differential .....	5-7	200424
5.5 Draining and filling, wheel hub .....	5-10	200424
5.6 Draining and filling, gearbox .....	5-12	200424
5.7 Draining and filling, retarder .....	5-14	200424
5.8 Filling the grease supply of the automatic lubrication system .....	5-15	200424
<b>6. CLEANING</b> .....	6-1	200424
<b>Cab and electrical system</b>		
6.1 Cleaning the interior filter element .....	6-1	200424
6.2 Cleaning the battery terminals .....	6-2	200424
<b>Engine, cooling system and fuel system</b>		
6.3 Cleaning the air filter element .....	6-3	200424
6.4 Cleaning the radiator and intercooler .....	6-4	200424
6.5 Cleaning the fuel coarse filter .....	6-5	200424
<b>Drive and chassis</b>		
6.6 Cleaning the vehicle .....	6-6	200424
<b>7. LUBRICATION</b> .....	7-1	200424
7.1 Lubricate according to lubrication schedule .....	7-1	200424

# EXPLANATORY NOTES ON THE MAINTENANCE ACTIVITIES

---

Contents

**95XF** series

**5**

## EXPLANATORY NOTES ON THE MAINTENANCE ACTIVITIES

95XF series

Safety instructions

### 1. SAFETY INSTRUCTIONS

Comply with all the warnings and safety precautions given in this maintenance manual.

First read the instructions and warnings on the labels and stickers which are affixed to various components on the vehicle and follow them. They are provided for your safety and health, so do not ignore them.

Wear clean, fitted clothes and apply protective cream to unprotected parts of your body, if necessary.

Do not run the engine in an enclosed or unventilated area. In other words, make sure that the exhaust gases are effectively extracted.

Remain at a safe distance from rotating and/or moving components.

Never remove the filler cap from the cooling system when the engine is at operating temperature.

Be careful when changing the oil. Hot oil may cause serious injuries.

Avoid unnecessary contact with drained oil. Frequent contact damages the skin.

Various kinds of oil and other lubricants used on the vehicle may constitute a health hazard. This also applies to engine coolant, windscreen washer fluid, refrigerant in air-conditioning systems, battery acid and diesel fuel. So avoid inhalation and direct contact.

When carrying out operations under the cab, make sure the cab is fully tilted and locked.

## EXPLANATORY NOTES ON THE MAINTENANCE ACTIVITIES

---

### Safety instructions

**95XF** series

To avoid the risk of fire, the engine and its surroundings should be kept free of inflammable fluids.

If an engine encapsulation is present, the encapsulation panels must be thoroughly cleaned after each inspection interval in view of the risk of fire if the inside of the panels should be dirty.

Always disconnect the earth connection of the battery before working on the vehicle.

Always use stands to support the chassis or components when working under the vehicle.

Always charge batteries in a properly ventilated area and avoid sparking and naked flames. Fast-charging should only be resorted to in an emergency. When fast-charging, the battery positive and negative leads (+ and -) must be disconnected.

**5**

## EXPLANATORY NOTES ON THE MAINTENANCE ACTIVITIES

95XF series

General

### 2. GENERAL

#### 2.1 INTRODUCTION

This maintenance manual describes all relevant maintenance activities. It also contains safety instructions, which must be strictly observed. Activities not described in this manual, e.g. overhaul, fault-finding, etc., are described in the DAF workshop instructions.

This maintenance manual assumes that the mechanic is sufficiently experienced and will have had sufficient instruction or training to carry out the maintenance activities in a responsible and safe manner.

The technical data and notes on the maintenance activities have been compiled with the utmost care.

#### 2.2 TECHNICAL INFORMATION

The technical information in this maintenance manual, such as notes on maintenance activities and technical data required to carry out the maintenance activities in a responsible manner, was up-to-date at the time this manual went to press.

DAF reserves the right to make changes without prior notice.

**Note:**

Important changes relating to technical information which are not contained or could not be contained in this maintenance manual will be published in a TI (Technical Information Sheet).

## EXPLANATORY NOTES ON THE MAINTENANCE ACTIVITIES

General

95XF series

### 2.3 WARNING SYMBOL

When text is accompanied by the warning symbol shown here, the information provided is essential for the health and personal safety of the mechanic.

This warning symbol is also shown if circumstances threaten the safety of the vehicle or could lead to damage to the vehicle.



M0015

### 2.4 ENVIRONMENT

By carrying out the maintenance activities in a professional manner, on time and at regular intervals, you will help reduce the impact on the environment.

This means, for example, noticing and remedying possible leakages in time and keeping the engine in an optimum condition (adjusting valves, replacing air filter element etc.), thus reducing the emission of harmful exhaust gases.

It should be noted that oils and fluids contain harmful substances that have a negative impact on the environment.

That is why you should take care that drained oils and fluids, but also discarded oil and fuel filters, are collected in separate receptacles or containers.

In short: **Maintenance activities must be carried out in an environmentally conscious manner.**

5



## EXPLANATORY NOTES ON THE MAINTENANCE ACTIVITIES

95XF series

General

### 2.5 PARTS

All DAF parts and components have been carefully attuned to each other, a decisive factor in ensuring the original DAF quality.

It is only logical, therefore, that the original DAF quality can best be maintained if original DAF parts and components are used when replacing parts or components.

As far as maintenance activities are concerned, you should think of windscreen-wiper blades, air-dryer elements, gaskets, V-belts and filters. If, for example, non-original DAF filters are used, the engine will be insufficiently protected against microscopically small airborne dust particles, almost imperceptible metal swarf in the oil and contaminated fuel, resulting in:

- premature replacing of cylinders, pistons, bearings, valves, injector pump and other moving parts
- reduced engine performance
- increased fuel consumption.

**Therefore, always use original DAF parts and components.**

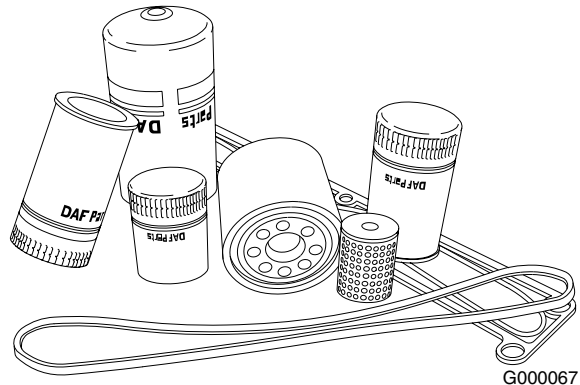

## EXPLANATORY NOTES ON THE MAINTENANCE ACTIVITIES

General

95XF series

### 2.6 MAINTENANCE GUIDELINES

- When carrying out maintenance activities on the vehicle, it is important that the work is performed under the cleanest possible conditions.  
Filler caps, lubricating points, level check and drain plugs should be cleaned before and after maintenance activities.
- When excessive leakage has been detected at oil seals and/or components, or in case of excessive oil-level decreases, a report should be made and the cause should be remedied.
- It is important to check the exhaust ports of the gearbox, transfer case, rear axle and driven front axle regularly for fouling and blocking.  
If the breathers are blocked by dirt, overpressure could cause leakage.
- Depending on the circumstances in which the vehicle is used, e.g. on very bad roads or construction sites, important bolt connections such as the fifth wheel, spring suspension, U-bolts, trailer coupling, steering box attachment, superstructure attachments etc. should be inspected more often and, if required, be retightened.
- It is important that a visual inspection and test run are carried out following the maintenance activities.  
Particular attention should be paid to components directly related to driving safety.
- Consult the DAF workshop instructions when welding at and/or drilling in the chassis.  
Welding to and/or drilling in wrong spots of the chassis will cause the material to weaken.

5

## EXPLANATORY NOTES ON THE MAINTENANCE ACTIVITIES

**95XF** series

General

- Always make sure that when welding at the vehicle the alternator wiring and the positive and negative battery leads are disconnected.  
Position the earth clamp as close as possible to the weld location. The earth clamp must never be attached to a rotating component such as propeller shaft, hub, fan etc., nor on an autonomous operating component in which there are rotating parts such as the compressor, turbo etc..

## **EXPLANATORY NOTES ON THE MAINTENANCE ACTIVITIES**

---

General

**95XF** series

**5**

## **EXPLANATORY NOTES ON THE MAINTENANCE ACTIVITIES**

**95XF** series

Inspection and adjustment

### **3. INSPECTION AND ADJUSTMENT**

#### **3.1 CHECKING THE PEDAL RUBBERS**

1. Check that the pedal rubbers are still securely mounted on the pedal.
2. Check that the pedal rubbers are not worn out and there is still sufficient tread.

## EXPLANATORY NOTES ON THE MAINTENANCE ACTIVITIES

Inspection and adjustment

95XF series

### 3.2 CHECKING THE BATTERY FLUID LEVEL



Avoid sparks and open flames in the vicinity of batteries. Battery acid is an aggressive fluid.

In the event of contact with the skin: rinse the skin with plenty of water for a sustained period. If redness or pain persists, consult a doctor. Remove any clothing affected and rinse with water.

In the event of contact with the eyes: rinse with plenty of water for at least 15 minutes and see a doctor.

If swallowed: do NOT induce vomiting. Rinse the mouth, drink two glasses of water and see a doctor.

In the event of inhalation: get some fresh air, rest and consult a doctor.

#### Checking the battery fluid level

1. Check the electrolyte level. The electrolyte level must be approx. 10 mm above the plates, or if present, up to the level indicator.
2. If required, top up the batteries, see "Draining and filling".

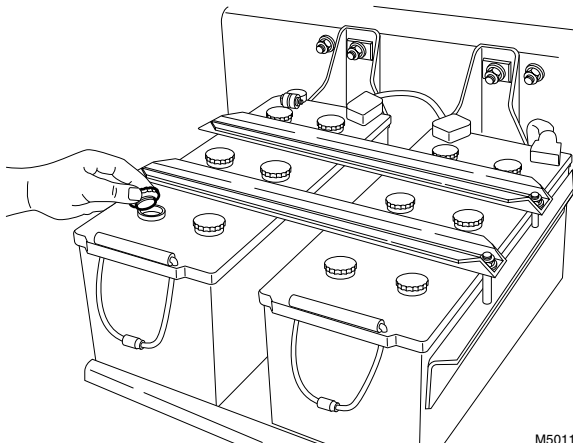

M5011

### 3.3 CHECKING THE BATTERY TERMINALS

1. Visually check the battery terminals for corrosion. Clean the battery terminals if necessary, see chapter "Cleaning".
2. Check the attachment of the battery clamps.

## EXPLANATORY NOTES ON THE MAINTENANCE ACTIVITIES

95XF series

Inspection and adjustment

### 3.4 INSPECTION AND ADJUSTMENT, HEADLIGHT SETTING

#### Checking the headlight setting

**Note:**

In view of the required precision we advise you to use the correct optical and electronic adjustment equipment, and always follow the manufacturer's instructions and advice.

If the correct equipment is not available, the setting of the headlights (dipped beam) can be checked as follows:

- The dipped beam should have a downward slant of 1%, which means that when it is projected on a board or wall at a distance of 10 metres, the light-dark division should be 10 cm below the centre height of the headlamp.
1. When checking the headlight setting (dipped beam) the vehicle must carry no load and the tyres should have the prescribed tyre pressure.
  2. Ensure that the vehicle is standing on a flat and level surface.
  3. Make sure that when checking the headlight setting, the rotary knob for the headlight adjustment, if available, is in its central "0" position.

#### Adjusting the headlight setting

1. Adjust the headlights using two adjusting bolts which can be reached through the openings in the headlight rim. Adjusting bolt (1) changes the vertical adjustment of the beam and adjusting bolt (2) the horizontal adjustment.

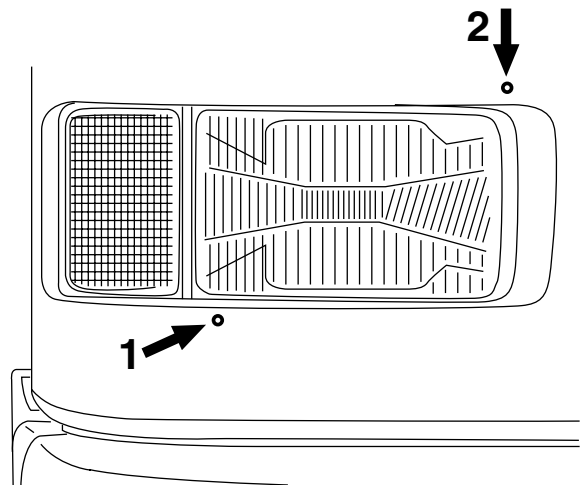

K100356

## EXPLANATORY NOTES ON THE MAINTENANCE ACTIVITIES

Inspection and adjustment

95XF series

### 3.5 CHECKING THE FLUID LEVEL OF THE CAB TILTING PUMP

1. The fluid level must be checked when the cab is tilted back.
2. The cock (2) should be in the "lowering" position (counter-clockwise).
3. Loosen filler plug (1) 3 to 4 turns and wait until the overpressure, if any, has left the reservoir. Now the filler plug can be removed.
4. Start pumping with a maximum of five pump strokes, making sure that the pump lever is in the lower position when finished.
5. Then check the fluid level. This level should be no more than 2 cm below the filling opening.  
Top up if necessary.
6. Fit the filler plug and hand-tighten it.

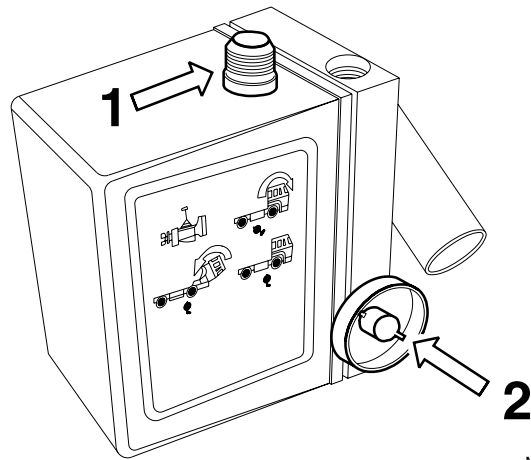

M1018

5

### 3.6 CHECKING THE CAB FASTENING

1. Check that all attachment bolts are present.
2. Visually inspect the attachment of the cab to the tilting mechanism.
3. Visually inspect the seals and condition of the tilting mechanism.

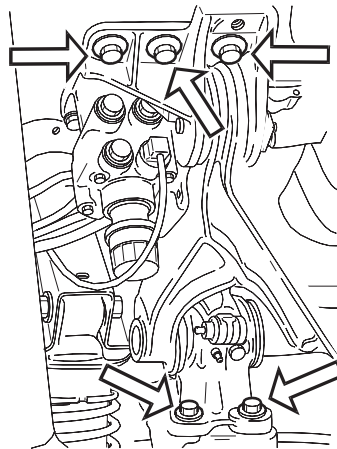

M1030



## EXPLANATORY NOTES ON THE MAINTENANCE ACTIVITIES

95XF series

Inspection and adjustment

### 3.7 INSPECTION AND ADJUSTMENT, VALVE CLEARANCE

#### XF/XE engine

1. Remove the valve covers. See "Removal and installation".
2. Place the fuel pump in the stop position. Lock the fuel pump in this position.
3. Use the special tool (DAF no. 1310477) to turn the crankshaft clockwise, as seen from the timing gear end (this is the engine's normal direction of rotation), until the valves of cylinder 1 overlap. The pistons of cylinders 1 and 6 are now at top dead centre.

**Note:**

"Overlap" is the moment at which the inlet valve starts opening and the exhaust valve finishes closing.

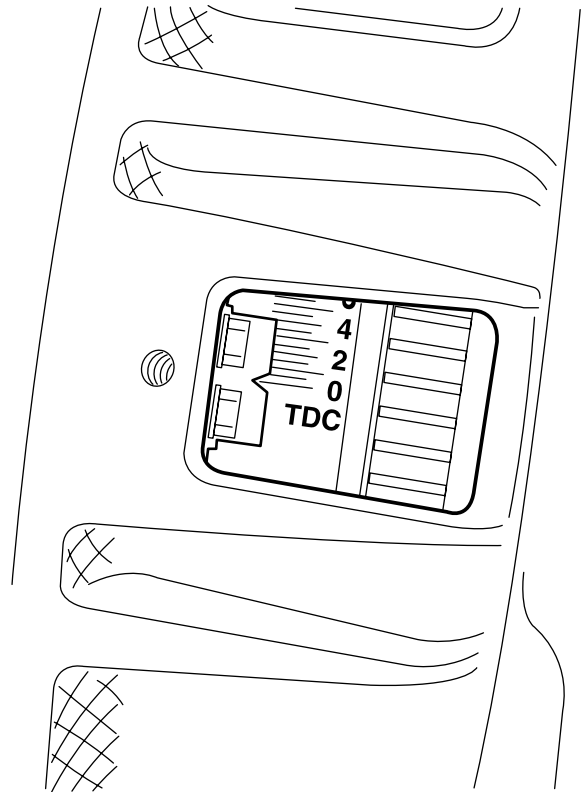

M200574

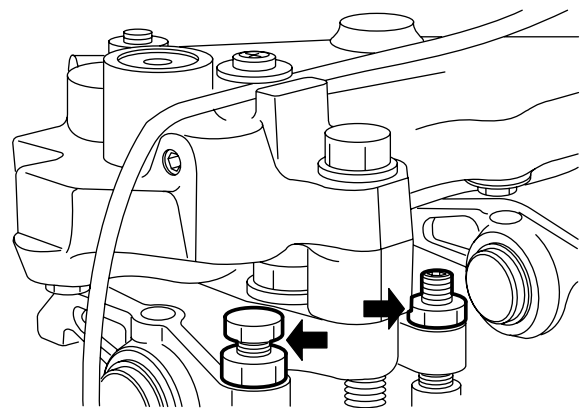

M200539

## EXPLANATORY NOTES ON THE MAINTENANCE ACTIVITIES

### Inspection and adjustment

95XF series

4. Check and correct the valve clearance of cylinder 6. The correct valve clearance is adjusted by loosening the lock nut and turning the adjusting bolt in the correct direction. See "Technical data" for the correct valve clearance.

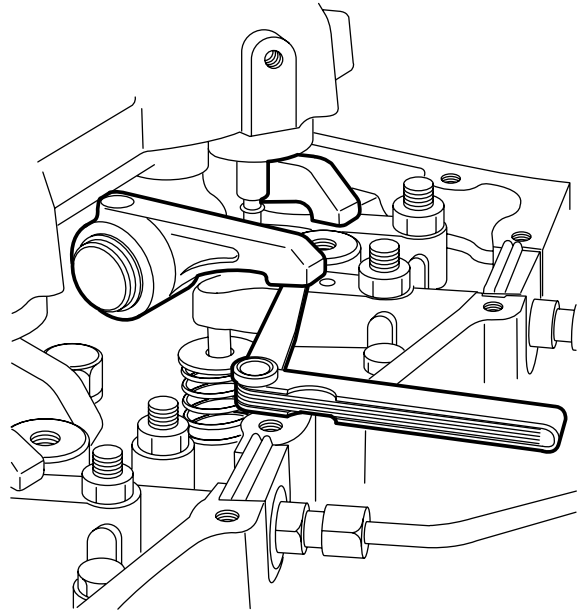

M200540

5

5. By always cranking the camshaft by 1/3 of a stroke using the special tool (DAF no. 1310477), the valves can be adjusted according to the injection sequence 1-5-3-6-2-4.

Valve overlap of cylinder	Set valves of cylinder
1	6
5	2
3	4
6	1
2	5
4	3

6. If the engine has been fitted with a DEB, the DEB clearance must be checked following the valve clearance adjustment.
7. Fit the valve covers. See "Removal and installation".

## EXPLANATORY NOTES ON THE MAINTENANCE ACTIVITIES

95XF series

Inspection and adjustment

### 3.8 INSPECTION AND ADJUSTMENT, DEB CLEARANCE

#### XF/XE engine

1. Remove the valve covers.
2. Tighten the DEB attachment bolts to the specified torque. See "Technical data".
3. Crank the engine in the direction of rotation until cylinder 1 has reached the top dead centre (TDC) and the valves of cylinder 6 overlap.
4. Use set screw (B) to set the DEB clearance (A) of cylinders 1, 3 and 5. See "Technical data". Then tighten set screw (B) to the specified torque. See "Technical data".
5. Crank the engine in the direction of rotation until cylinder 6 has reached the top dead centre (TDC) and the valves of cylinder 1 overlap.
6. Use set screw (B) to set the DEB play (A) of cylinders 2, 4, and 6, see "Technical data". Then tighten set screw (B) to the specified torque. See "Technical data".
7. Fit the valve covers.

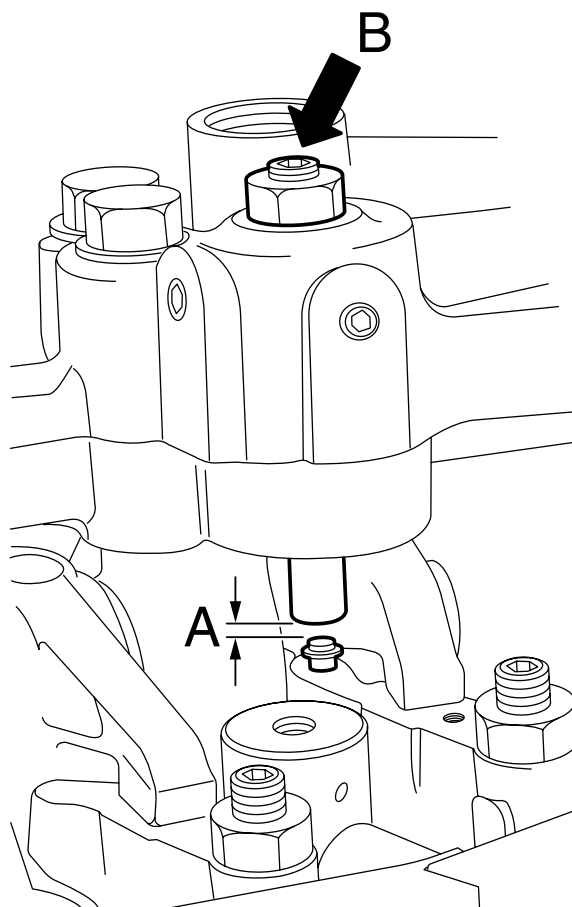

i 400166

5

# EXPLANATORY NOTES ON THE MAINTENANCE ACTIVITIES

Inspection and adjustment

95XF series

## 3.9 INSPECTION AND ADJUSTMENT, VALVE CLEARANCE AND UNIT INJECTORS

### VF engine

**Note:**

- The valve clearances and unit injectors must be adjusted when the engine is cold ( $\leq 60^{\circ}\text{C}$ ).
- Each cylinder has three rockers:
  1. The rocker for the exhaust valves
  2. The rocker for the unit injector
  3. The rocker for the inlet valves.

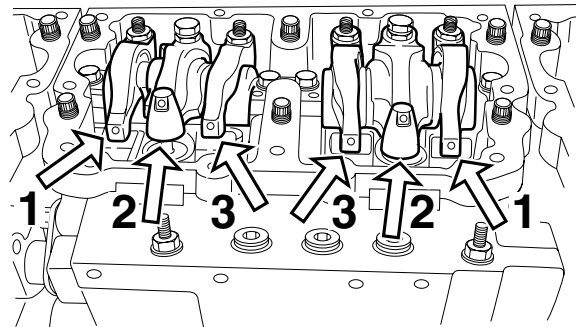

M2146

- For the correct adjusting procedure for inlet and exhaust valves and unit injectors, use the marks made on the accessory drive pulley (1) for the air-conditioning compressor and water pump.
- The direction of rotation of the crankshaft is clockwise, as seen from the front of the engine.
- Cylinder 1 is on the timing-gear end, and cylinder 6 on the flywheel end.
- The injection sequence is 1-5-3-6-2-4.
- Using the table below, and the marks on the drive pulley and timing-gear cover, it is possible to adjust the inlet and exhaust valves and unit injectors of the cylinders indicated.

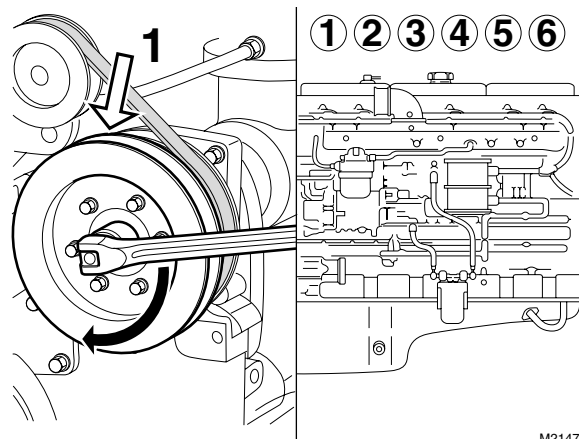

M2147

Marks on drive pulley:  
Adjustment of inlet and exhaust valves and unit injectors of cylinder:

A	1 or 6
B	5 or 2
C	3 or 4

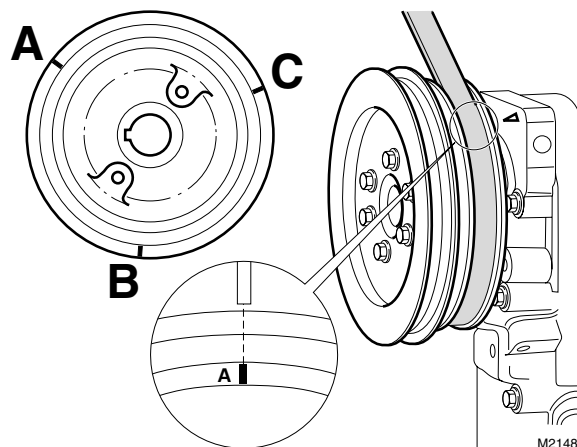

M2148

## EXPLANATORY NOTES ON THE MAINTENANCE ACTIVITIES

95XF series

Inspection and adjustment

1. Disconnect the battery earth lead.
2. Remove the valve covers. See "Removal and installation".
3. If the vehicle is equipped with a C-brake, the C-brake must be removed first, see chapter "Removal and installation".
4. Tighten the rocker shaft attachment bolts to the specified torque. See "Technical data".

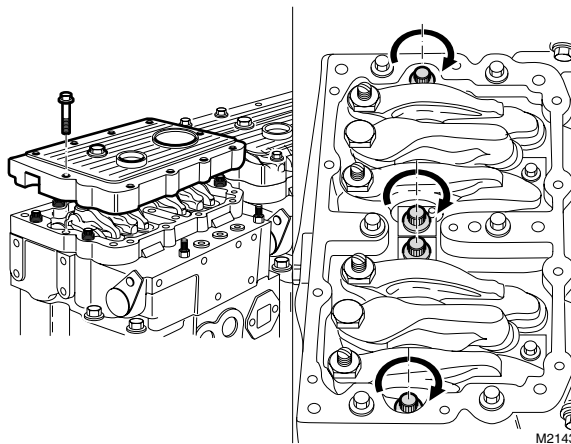

5. Tighten the rocker-housing attachment bolts, in the order shown in the diagram, to the specified torque. See "Technical data".

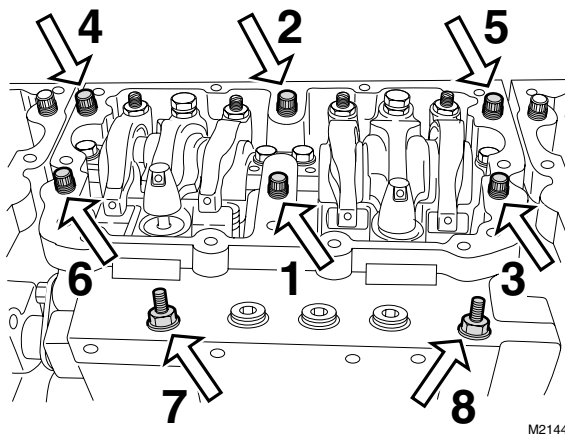

6. Tighten the attachment bolts of the unit injectors to the specified torque, see "Technical data".

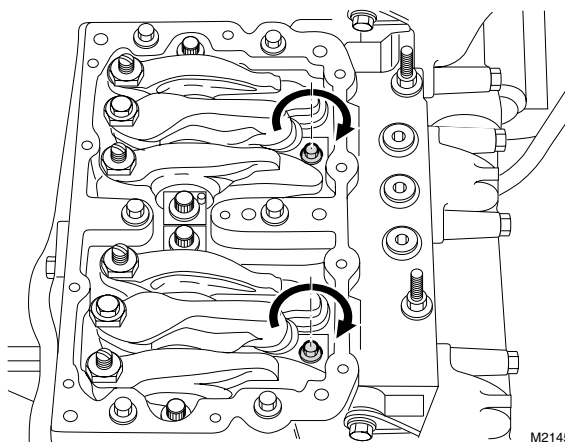

5

## EXPLANATORY NOTES ON THE MAINTENANCE ACTIVITIES

### Inspection and adjustment

95XF series

7. Rotate the drive pulley (in the direction of rotation of the crankshaft) using the attachment nut on the pulley, until the "A" marking is in line with the marking on the timing cover.
8. Check that the inlet and exhaust valves of cylinder 1 are closed.

**Note:**

The valves are closed if both rockers can be moved from side to side.

If necessary, rotate the drive pulley through 360° until the "A" marking is once again in line with the marking on the cylinder block.

9. Now adjust the valve clearance and the unit injector of cylinder 1.
10. Repeat this adjustment procedure for the remaining cylinders. Consult the following table to this end.

Marks on drive pulley:

Adjustment of inlet and exhaust valves and unit injectors of cylinder:

A	1 or 6
B	5 or 2
C	3 or 4

11. If required, fit the C-brake, see chapter "Removal and Installation".
12. Fit the valve covers. See "Removal and installation".

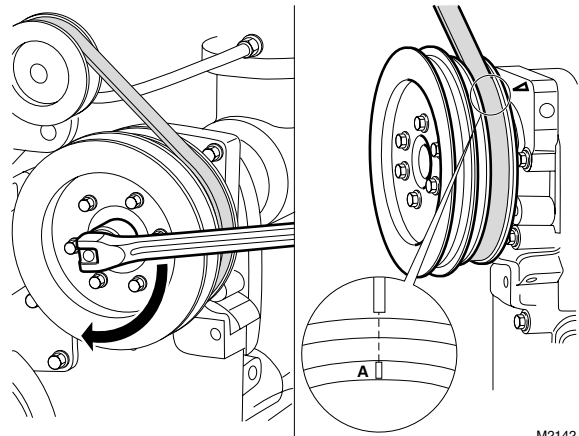

M2142

## EXPLANATORY NOTES ON THE MAINTENANCE ACTIVITIES

95XF series

Inspection and adjustment

### Adjusting the valve clearance

1. Slacken the lock nut of the adjusting bolt.
2. Using a feeler gauge and special tool (DAF no. 1240043), adjust the specified valve clearance, see "Technical data".
3. Tighten the adjusting bolt using special tool (DAF no. 1240043) before removing the feeler gauge.  
The specified torque is 0.56 - 0.68 Nm.

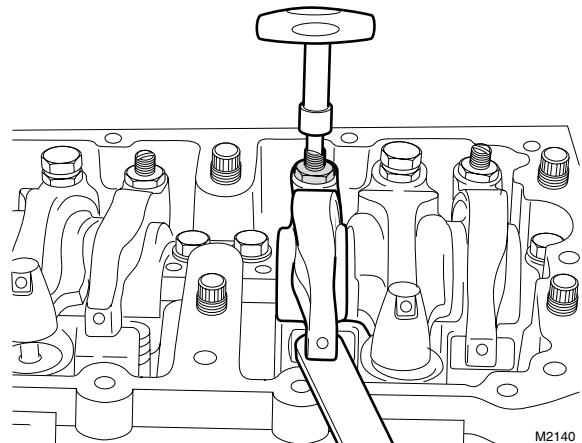

4. Hold the adjusting bolt in this position, and tighten the lock nut using special tool (DAF no. 1240042) to the specified tightening torque, see "Technical data".

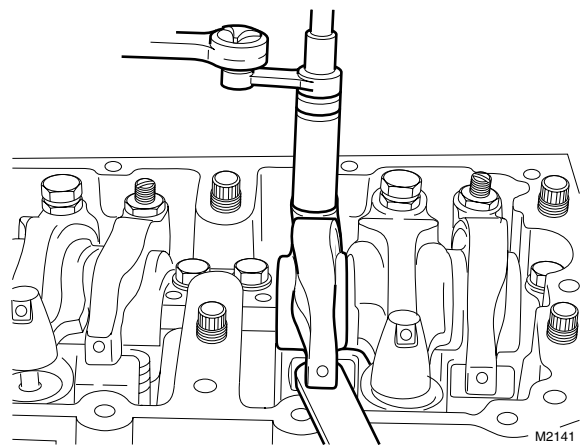

## EXPLANATORY NOTES ON THE MAINTENANCE ACTIVITIES

Inspection and adjustment

95XF series

### Adjusting the unit-injector

1. Slacken the lock nut of the adjusting bolt.
2. Turn the adjusting bolt three to four times clockwise and anti-clockwise. This will force the fuel beneath the injector plunger out, thus moving the injector plunger downwards.

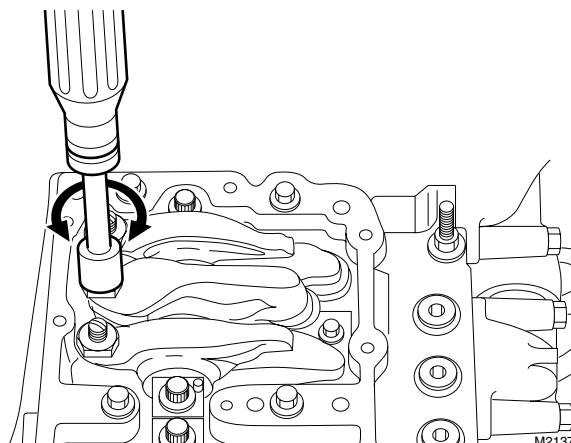

3. Then screw the adjusting bolt clockwise until there is clear, considerable resistance. Do not turn the adjusting bolt further in clockwise direction to avoid damage.

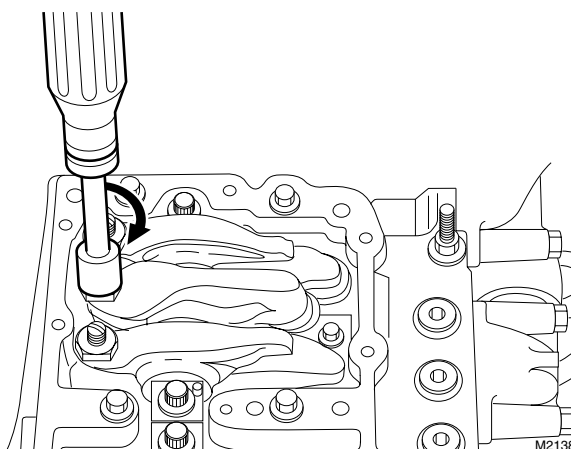

4. Turn the adjusting bolt 120° anti-clockwise. This equals a clearance of 0.55 mm (setting value may be between 0.50 and 0.75 mm).
5. Hold the adjustment bolt in this position and tighten the lock nut to the specified tightening torque, see "Technical data".

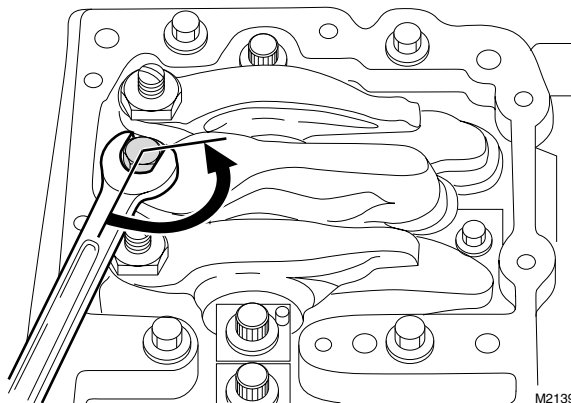

5



## EXPLANATORY NOTES ON THE MAINTENANCE ACTIVITIES

95XF series

Inspection and adjustment

### 3.10 INSPECTION AND ADJUSTMENT, C-BRAKE PLAY

#### VF engine

##### Note:

- The C-brake must be adjusted when the engine is cold ( <math><60^{\circ}\text{C}</math>).
- Use a dial gauge for C-brake adjustments.
- Each cylinder has three rockers:
  1. The rocker for the exhaust valves (1)
  2. The rocker for the unit injector (2)
  3. The rocker for the inlet valves (3).

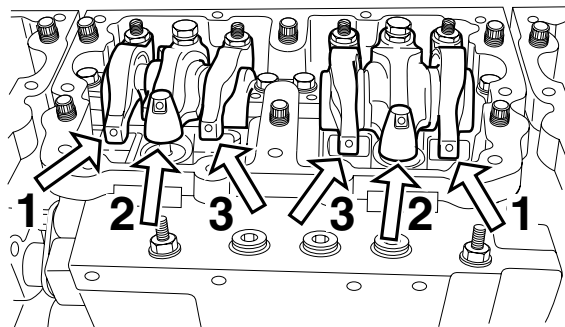

M2146

- For a correct setting of the C-brake, use the set marks shown on the accessory drive pulley (1) for the air-conditioning compressor and the water pump.
- The direction of rotation of the crankshaft is clockwise, as seen from the front of the engine.
- Cylinder 1 is on the timing-gear end, and cylinder 6 on the flywheel end.
- The injection sequence is 1-5-3-6-2-4.

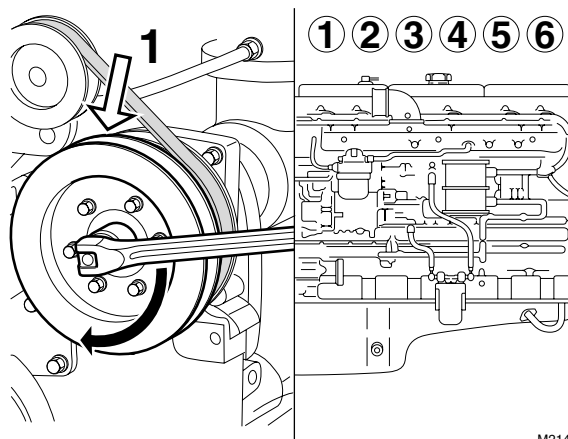

M2147

## EXPLANATORY NOTES ON THE MAINTENANCE ACTIVITIES

### Inspection and adjustment

95XF series

- The C-brakes of the specified cylinders can be set using the table below and the marks on the drive pulley and on the timing cover.

Marks on drive pulley:

Adjustment of cylinder C-brake:

A	5 or 2
B	3 or 4
C	1 or 6

1. Disconnect the battery earth lead.
2. Remove the valve covers. See "Removal and installation".
3. Rotate the drive pulley (in the direction of rotation of the crankshaft) using the attachment nut on the pulley, until the "A" marking is in line with the marking on the timing cover.
4. Check that the inlet and exhaust valves of cylinder 5 are closed.

**Note:**

The valves are closed if both rockers can be moved from side to side.

If necessary, rotate the drive pulley through 360° until the "A" marking is once again in line with the marking on the timing cover. Now set the C-brake of cylinder 5.

5. Slacken the lock nut of the adjusting bolt.
6. Tighten the adjusting bolt clockwise until you clearly feel resistance (the C-brake plunger is now in contact with the exhaust-valves bridge).

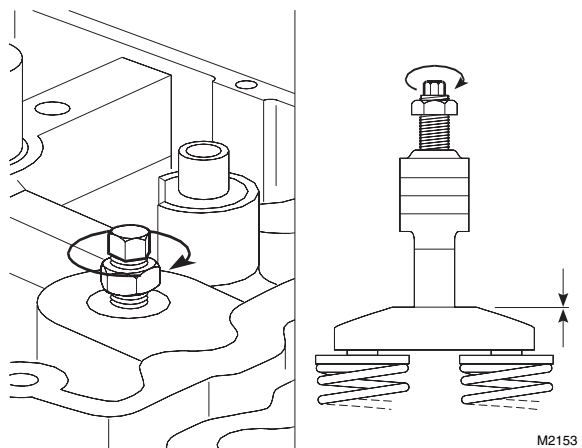
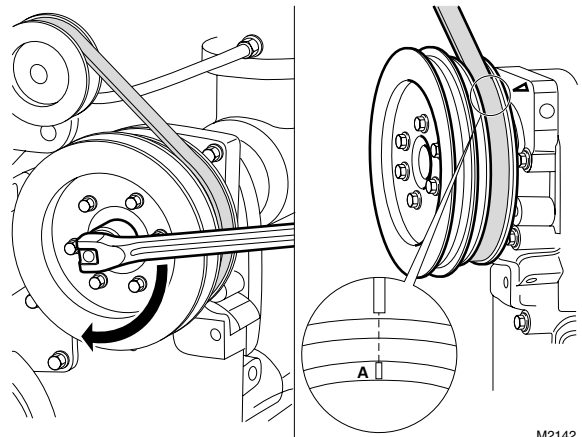
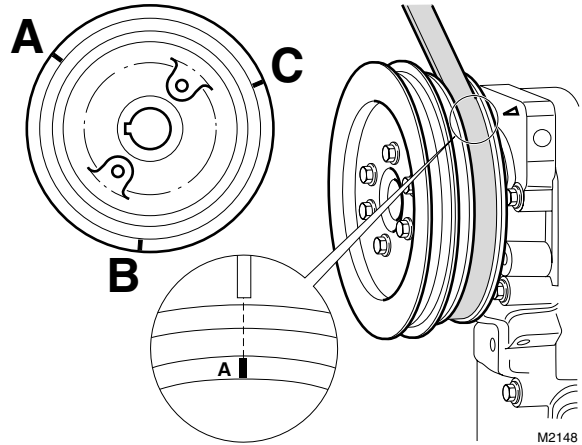

## EXPLANATORY NOTES ON THE MAINTENANCE ACTIVITIES

95XF series

Inspection and adjustment

7. Install a dial gauge.
8. Set the dial gauge to "0".
9. Turn the adjusting bolt counter-clockwise until the value on the dial gauge equals the C-brake setting value, see "Technical data".

**Note:**

The setting value is also shown on the shield (1) fitted on the C-brake housing.

10. Tighten the lock nut to the specified tightening torque. See "Technical data". Use special tool (DAF no. 1240042).
11. Repeat this adjustment procedure for the remaining cylinders. Consult the following table to this end.

Marks on drive pulley:

Adjustment of cylinder C-brake:

A	5
B	3
C	6
A	2
B	4
C	1

12. Fit the valve covers. See "Removal and installation".

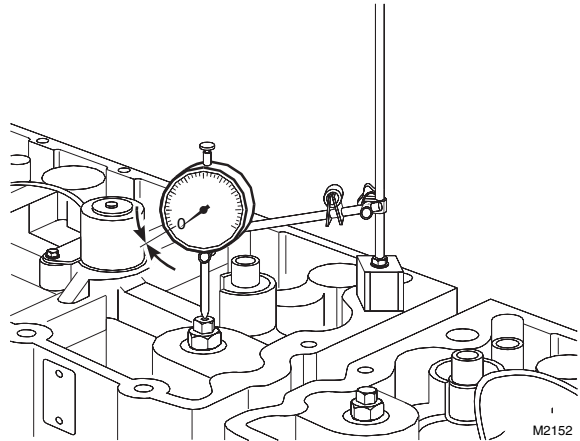

## EXPLANATORY NOTES ON THE MAINTENANCE ACTIVITIES

Inspection and adjustment

95XF series

### 3.11 INSPECTION AND ADJUSTMENT, V-BELT TENSION

XF/XE engine

#### Checking the V-belt tension

1. Check the V-belt tension using special tool (DAF no. 1240442) for the single V-belts and using special tool (DAF no. 1240443) for the multiple V-belts or poly V-belts.

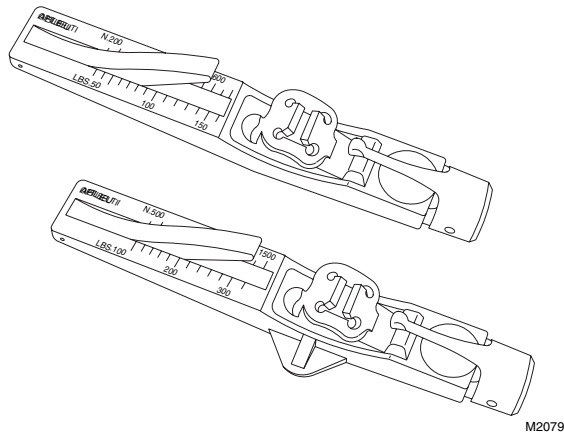

M2079

2. Set the gauge to zero by depressing the measuring arm (1).

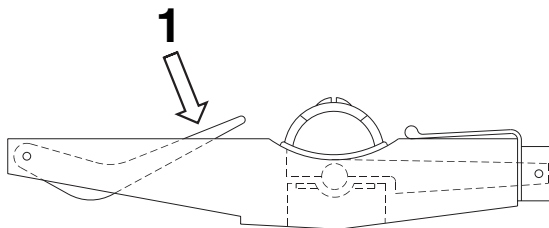

M2061

3. Place the belt tension gauge on the V-belt, halfway between the two pulleys.
4. Slowly depress the V-belt by means of the belt tension gauge until a click is heard. Carefully remove the gauge. Make sure that the measuring arm is not moved.

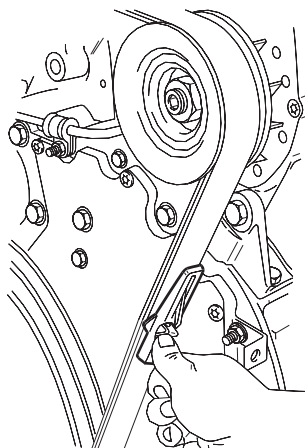

M2091

## EXPLANATORY NOTES ON THE MAINTENANCE ACTIVITIES

**95XF** series

Inspection and adjustment

5. Take the reading as indicated by the position of the measuring arm in relation to the scale. Compare this reading with the recommended pre-tension figure. See "Technical data".

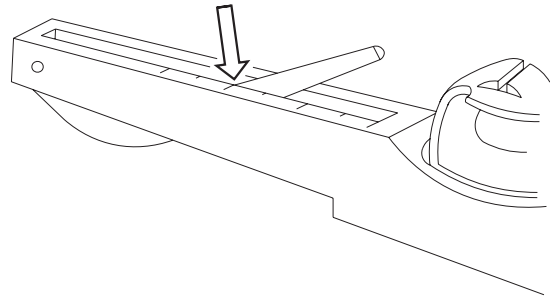

M2062

## EXPLANATORY NOTES ON THE MAINTENANCE ACTIVITIES

Inspection and adjustment

95XF series

### Adjusting the V-belt tension of the air conditioning compressor drive

1. Loosen the upper attachment bolt (1) on the compressor.
2. Loosen the lower attachment bolt (2) on the compressor.
3. Loosen the attachment bolt from the threaded spindle which is attached to the coolant pump.
4. Reposition the compressor using the lock nuts (3) until the correct V-belt tension is achieved. See "Technical data".

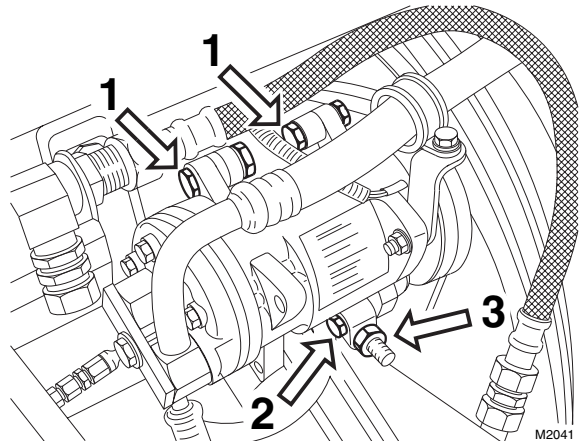

### Adjusting the V-belt tension of the water pump and alternator drive

1. Loosen the lock nut (4) of the threaded spindle.
2. Loosen the attachment bolt (3) of the threaded spindle that is fixed to the water pump.
3. Slacken the alternator bracket attachment bolts (1) and (2).
4. Reposition the alternator using the lock nut (5) until the correct V-belt tension is achieved. See "Technical data".
5. Tighten the threaded spindle and alternator attachment bolts.
6. Tighten the lock nuts of the threaded spindle.

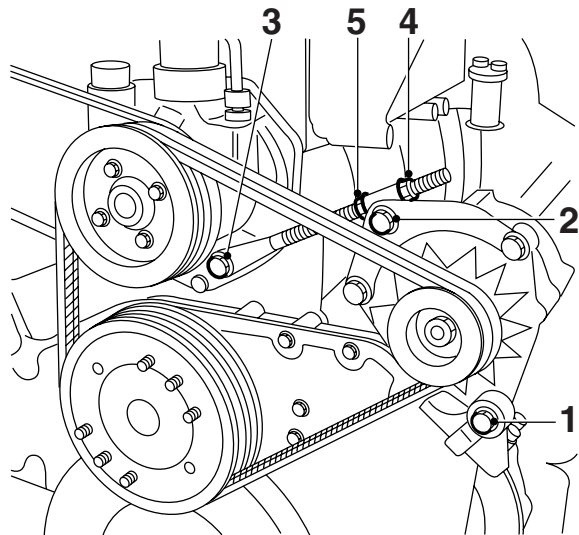

5

## EXPLANATORY NOTES ON THE MAINTENANCE ACTIVITIES

95XF series

Inspection and adjustment

### VF ENGINE

#### Checking the V-belt tension

1. Check the V-belt tension using special tool (DAF no. 1240442) for the single V-belts and using special tool (DAF no. 1240443) for the multiple V-belts or poly V-belts.

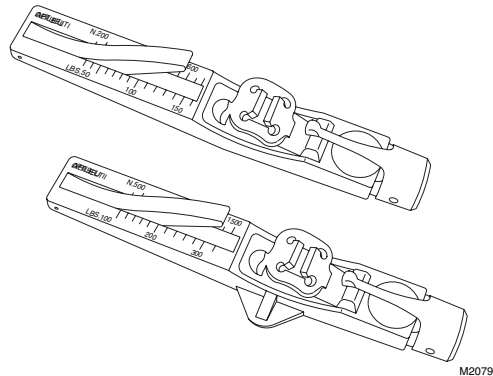

2. Set the gauge to zero by depressing the measuring arm (1).

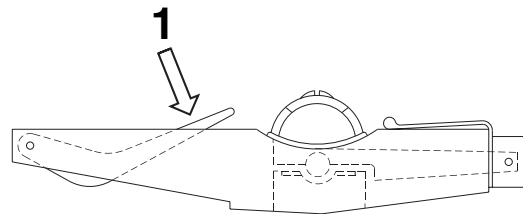

3. Place the belt-tension gauge on the V-belt, halfway between the two pulleys.
4. Slowly depress the V-belt by means of the belt tension gauge until a click is heard. Carefully remove the gauge. Make sure that the measuring arm is not moved.

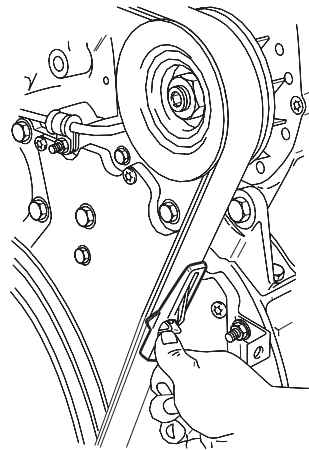

5. Take the reading as indicated by the position of the measuring arm in relation to the scale. Compare this reading with the recommended pre-tension figure. See "Technical data".

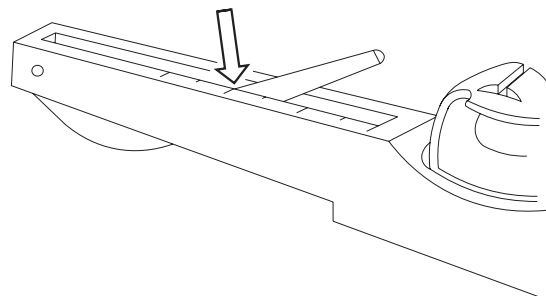

## EXPLANATORY NOTES ON THE MAINTENANCE ACTIVITIES

Inspection and adjustment

95XF series

### Adjusting the V-belt tension of the air conditioning compressor drive

1. Slacken the attachment bolt (1) in the clamping block (2) and slacken the attachment bolt of the threaded spindle on the cylinder block.
2. Slacken the attachment bolts on the compressor.
3. Reposition the compressor using the lock nuts (3) until the correct V-belt tension is achieved. See "Technical data".

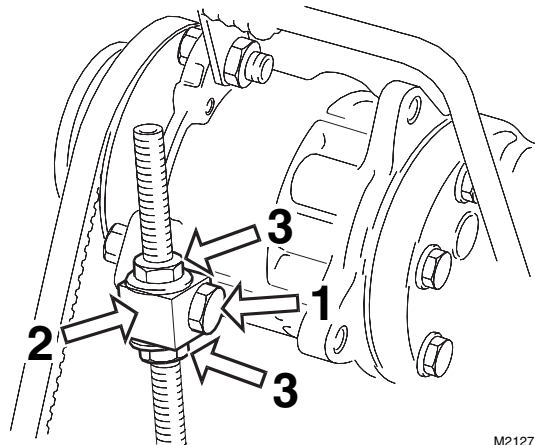

### Adjusting the belt (10-rib) tension of fan and alternator drive

1. Slacken the attachment bolt (1) in the clamping block (2) and slacken the attachment bolt of the threaded spindle on the cylinder block.
2. Slacken the attachment bolt (3) in the alternator support.
3. Shift the alternator using the lock nuts (4) until the correct belt tension is achieved, see "Technical data".

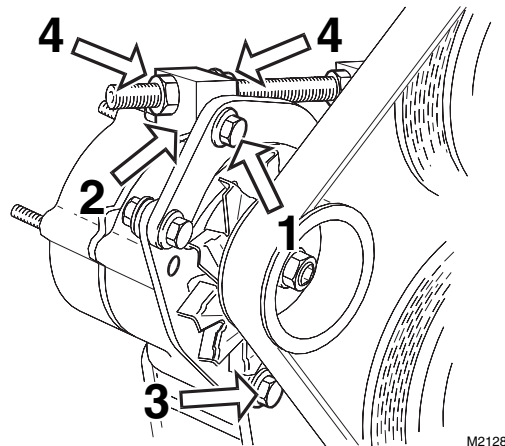

### Adjusting the belt (6-rib) tension of water pump drive

1. Slacken the central nut (1) of the tensioner.
2. Shift the tensioner using the bolt (2) until the correct belt tension is achieved, see "Technical data".

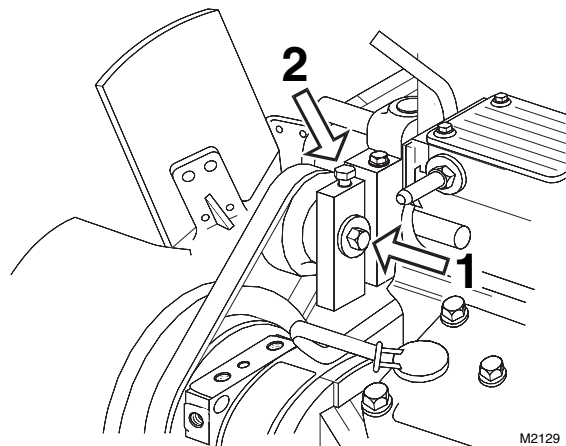



## EXPLANATORY NOTES ON THE MAINTENANCE ACTIVITIES

95XF series

Inspection and adjustment

### 3.12 CHECKING THE ANTIFREEZE CONTENT IN THE COOLING SYSTEM



When the coolant is hot, there is an overpressure in the cooling system. Carefully remove the filler cap to release the overpressure.

Coolant is a toxic fluid. Contact with the skin should therefore be avoided.

In order to avoid damaging the cylinder block, do not top up a warm engine with cold coolant.

1. Check the antifreeze content of the coolant. Fill the cooling system with antifreeze, if this has not been done yet. Always use only those coolants or antifreeze agents which meet DAF specifications.
2. Consult the manufacturer's instructions for the correct antifreeze mixing ratio. Preferably, use 40% antifreeze, on an ethylene glycol base. At this percentage, not only good frost protection, but also good corrosion protection is guaranteed.

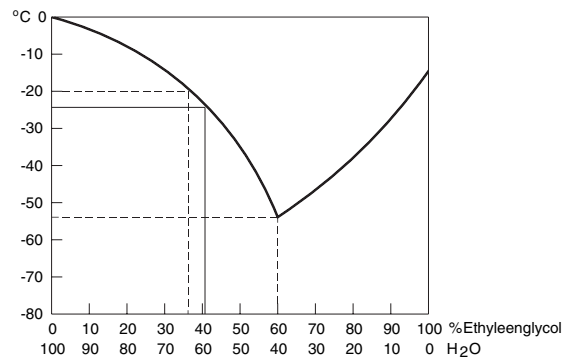

M2016

5

## EXPLANATORY NOTES ON THE MAINTENANCE ACTIVITIES

Inspection and adjustment

95XF series

### 3.13 CHECKING THE RACOR FILTER ELEMENT FOR WATER SEPARATION

1. If necessary, open drain plug (8) and pump the water out using the feed pump (1).
2. Close the drain plug (8).

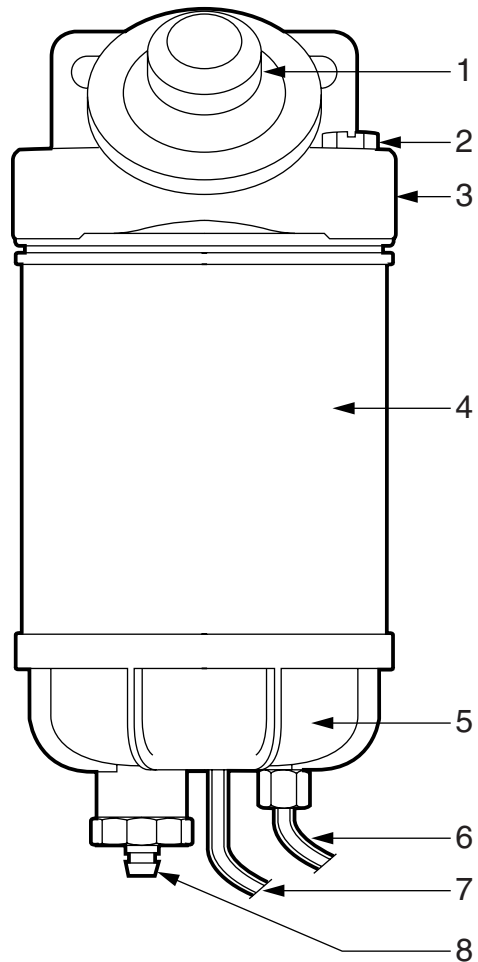

i400356

5

### 3.14 CHECKING THE EXHAUST SYSTEM

1. Visually inspect the exhaust system for leaks.
2. Check the exhaust suspension points.

## EXPLANATORY NOTES ON THE MAINTENANCE ACTIVITIES

95XF series

Inspection and adjustment

### 3.15 BLEEDING THE FUEL SYSTEM

#### Bleeding the fuel system with Racor filter



**While bleeding the fuel system, fuel will escape. Collect this fuel, bearing in mind the risk of fire.**

1. Open the bleed screw (2) on the filter housing.
2. Using the hand pump (1), pump fuel through the system until fuel without air bubbles flows through the bleed screw.
3. Close the bleed screw (2).

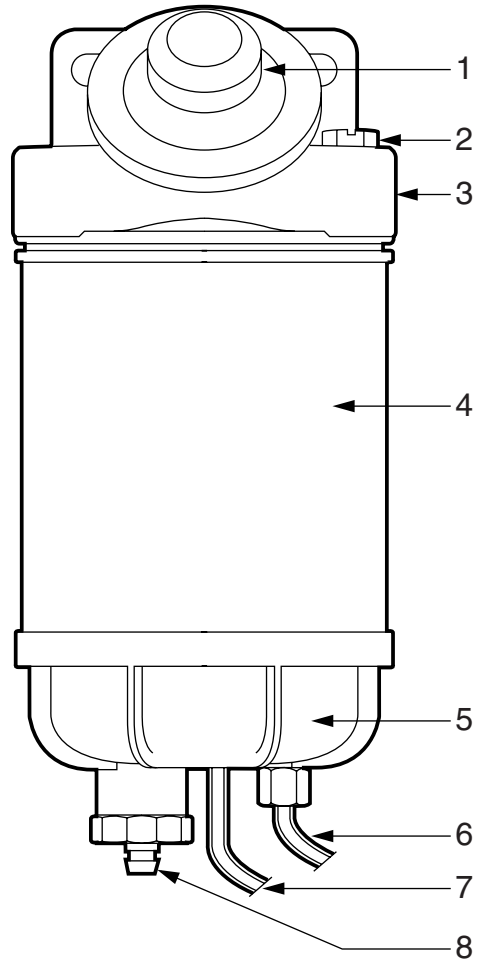

i400356

5

## EXPLANATORY NOTES ON THE MAINTENANCE ACTIVITIES

Inspection and adjustment

95XF series

### Bleeding the XF engine fuel system



**While bleeding the fuel system, fuel will escape. Collect this fuel, bearing in mind the risk of fire.**

1. Open the bleed screw (1) on the filter housing.
2. Using the hand pump (2), pump fuel through the system until fuel without air bubbles flows through the bleed screw.
3. Close the bleed screw (1).

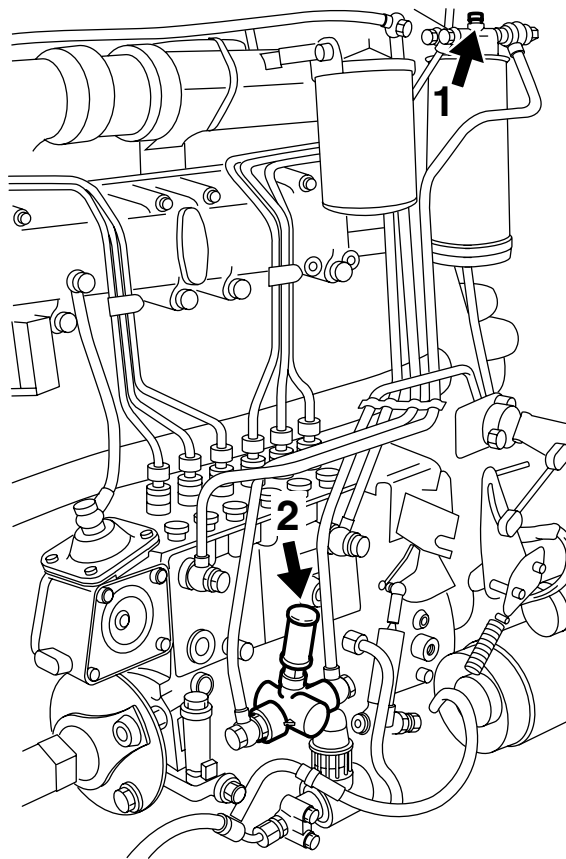

i 400172

5

### Bleeding the XE engine fuel system



**While bleeding the fuel system, fuel will escape. Collect this fuel, bearing in mind the risk of fire.**

**Dirt in the fuel system can lead to significant damage to pump units and housing.**

1. Open the bleed screw (1) on the filter housing.
2. Using the hand pump (2), pump fuel through the system until fuel without air bubbles flows through the bleed screw.
3. Close the bleed screw (1).

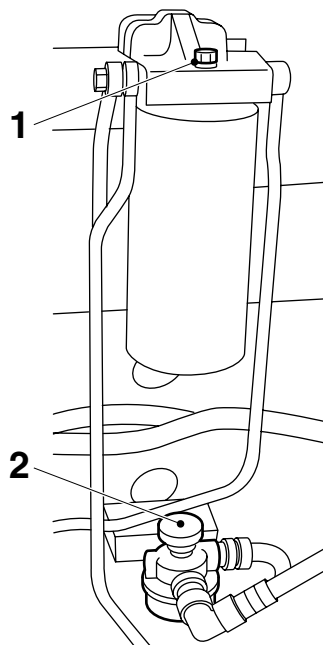

i 400252

## EXPLANATORY NOTES ON THE MAINTENANCE ACTIVITIES

95XF series

Inspection and adjustment

### 3.16 CHECKING THE GLOW COILS

**Note:**

To avoid engine damage it is important that the glow coils be checked periodically.

1. Check the glow coils for the following points:
  - windings that have worn thin due to abrasion (A);
  - coil end broken or worn thin due to continuous knocking of a loose insulator (B);
  - broken coil windings (C).
2. Replace all glow plugs if one or more of the above-mentioned situations occur.

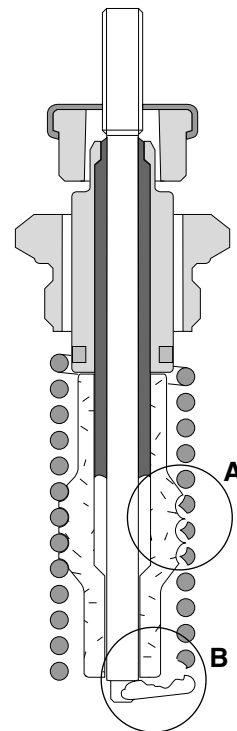
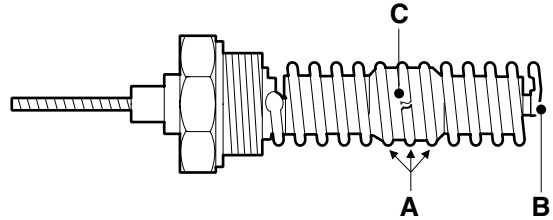

M200818

## EXPLANATORY NOTES ON THE MAINTENANCE ACTIVITIES

Inspection and adjustment

95XF series

### 3.17 CHECKING THE RADIATOR AND INTERCOOLER FOR FOULING

Visually inspect the radiator and intercooler for fouling. If required, clean the radiator and intercooler, see "Cleaning".

### 3.18 CHECKING THE STEERING OIL LEVEL

1. Clean the dipstick and its immediate surroundings so that no dirt can get into the reservoir.
2. Check the fluid level in the reservoir using the dipstick (1).
3. The fluid level should reach the upper dipstick mark (maximum) when the engine is running. When the engine is not running, the fluid level should be approx. 2 centimetres higher.

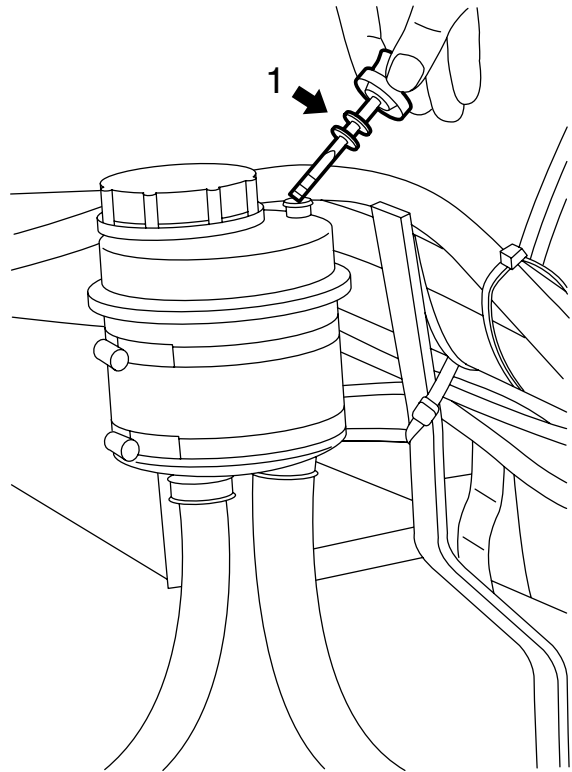

S700173

## EXPLANATORY NOTES ON THE MAINTENANCE ACTIVITIES

95XF series

Inspection and adjustment

### 3.19 CHECKING THE STEERING GEAR PIPES AND CONNECTIONS

1. Condition of the pipes
  - Check all pipes for tightness and wear.  
When one or more supply pipes is subject to negative pressure, it is especially likely that porous pipes will give rise to faults (air in the system).
  - If in doubt, always replace the pipe.
2. Pipe connections
  - Check each pipe connection for leaks.
3. Pipe routing
  - Pipes must not be twisted during fitting. A mark (sometimes in the form of text) can be put on the hose to make it easier to carry out this check.
  - Pipes must not touch other components (to prevent chafing).
  - Pipes should not bend sharply; this applies especially to the flexible suction and delivery pipes.
  - Pipes must not be pinched off by other components.

## EXPLANATORY NOTES ON THE MAINTENANCE ACTIVITIES

Inspection and adjustment

95XF series

### 3.20 CHECKING THE STEERING BALL JOINTS

#### Checking the locking devices and dust cover

1. Check whether the locking devices are present and undamaged.
2. Check that the dust cover of the steering ball joint and its seal are not damaged. Replace the steering ball joint if they are damaged.

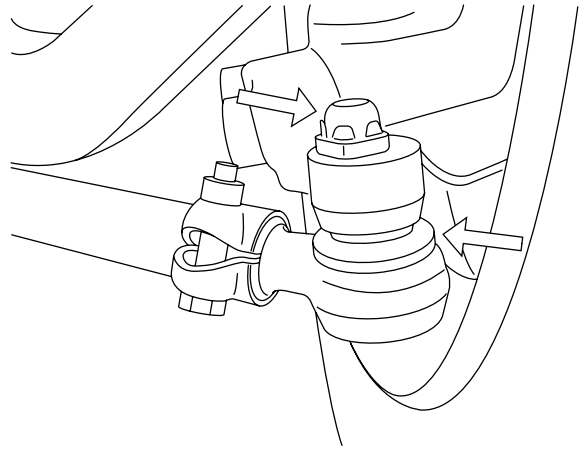

S700430

5

#### Checking the axial steering ball joint play

1. Check the axial steering ball joint play using the special tool (DAF no. 1329426).
2. First jack up the axle until the wheels come off the ground and put the axle on stands.
3. Make sure that the castle nut split pin (if present) does not come into contact with the ends of the threaded end.
4. Screw the thrust washer (8) onto the threaded spindle.
5. Fit the spring retainer (3), spring (4) and thrust sleeve (6) into bracket (1). Fit the locking screw (5). It should be possible to move the thrust sleeve (6) freely.

#### Note:

Fit the correct thrust sleeve (6).  
The thrust sleeve (6) must abut the rim of the steering ball joint (7).

6. Loosen thrust bolt (2) until the flange of the thrust sleeve (6) abuts the bracket ( $A = 0$  mm).
7. Fit the special tool to the steering ball joint (7) and turn the threaded spindle (9) by hand until the special tool is tight around the steering ball joint (7).
8. Tighten the thrust bolt (2) until its head abuts the bracket (1).



## EXPLANATORY NOTES ON THE MAINTENANCE ACTIVITIES

95XF series

Inspection and adjustment

9. Measure the play "A" between the thrust sleeve and the bracket using a feeler gauge. Compare the measured play with the maximum allowable steering ball joint play. See "Technical data".  
If necessary, replace the steering ball joint.

### 3.21 CHECKING THE BRAKE COMPONENTS/BRAKE SYSTEM FOR LEAKS

While operating the service brake, check whether any leaks occur in the brake system.

If the brake system of a vehicle has been charged to the maximum pressure, it should generally be possible to drive the vehicle after a period of 16 hours of uninterrupted standstill, without having to first charge the brake system to sufficient operating pressure.

This comes down to a maximum pressure drop of approx. 0.4 bar per hour at a normal system pressure.

**Note:**

Auxiliary consumers and accessories must always be connected to circuit 4.

## EXPLANATORY NOTES ON THE MAINTENANCE ACTIVITIES

Inspection and adjustment

95XF series

### 3.22 CHECKING THE BRAKE LINING THICKNESS

#### Checking the brake lining thickness (FTP axle excepted)

1. Pressurise the air brake system (pressure switch should cut out) and make sure that the vehicle's parking brake is not activated.
2. Check the brake lining thickness through the openings in the dust cover.
3. Replace the brake lining if it is worn down to the wear indicator mark on the brake lining.

**Note:**

If in doubt about the amount of brake lining wear, release the brakes and remove the dust cover.

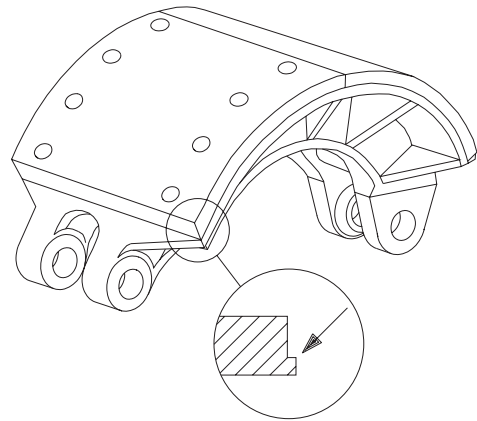
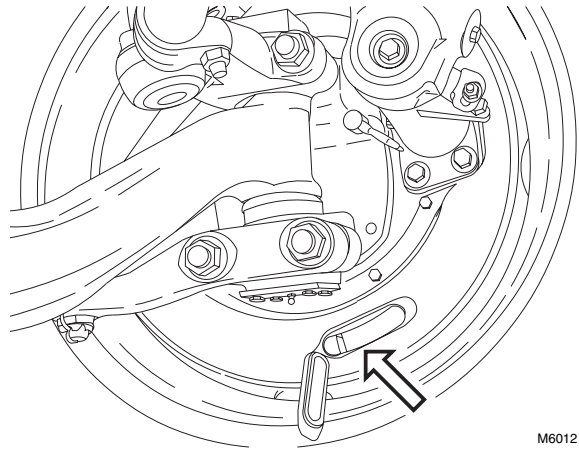

#### Checking the brake lining thickness (FTP axle)

1. Pressurise the air brake system (pressure switch should cut out) and make sure that the vehicle's parking brake is not activated.
2. Check the brake lining thickness through the openings in the dust cover.
3. Replace the brake lining if it is worn down to the wear indicator mark on the brake lining.

**Note:**

If in doubt about the amount of brake lining wear, release the brakes and remove the dust cover.

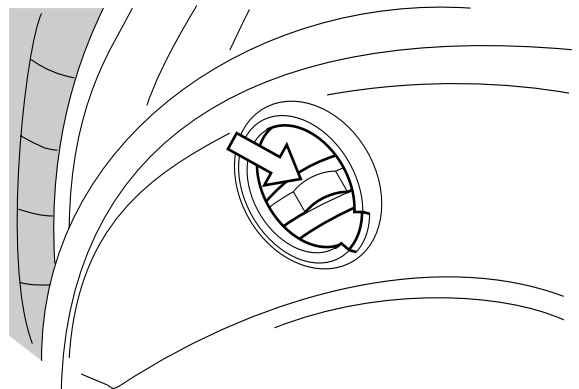

## **EXPLANATORY NOTES ON THE MAINTENANCE ACTIVITIES**

**95XF** series

Inspection and adjustment

### **3.23 CHECKING THE BRAKE CYLINDER FASTENING**

1. Check that the brake cylinders do not move during operation of the service brake.

## EXPLANATORY NOTES ON THE MAINTENANCE ACTIVITIES

Inspection and adjustment

95XF series

### 3.24 CHECKING THE AUTOMATIC BRAKE ADJUSTER

#### Checking the brake adjuster travel

1. Measure the basic setting L1.
2. Measure the position when the brakes are applied, L2 (minimum brake system pressure 6 bar).
3. Calculate the brake adjuster travel L3 ( $L3 = L2 - L1$ ). Compare the calculated value to the specified value, see "Technical data".
4. If the brake adjuster travel differs considerably from the specified value, take the following action:
  - Check whether the control plate (1) is locked in respect of the fixed bracket.

If not, turn the control plate as far as possible (until the internal stop is felt) in the direction in which the brake adjuster is moved during braking.

Fix the control plate in **this** position, via the attachment nut on the fixed bracket.

- Check the internal slip using a torque wrench.

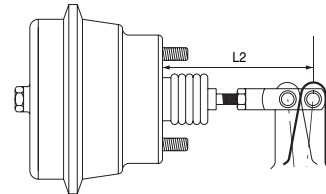
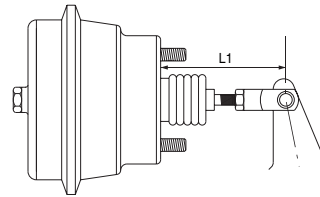

M6101

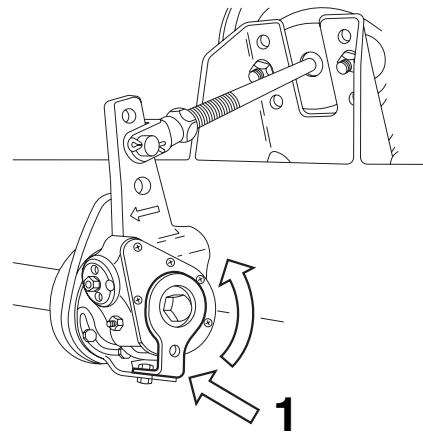

M6005

#### Checking the internal slip

1. Make certain that there is sufficient pressure in the reservoirs (min. 6.5 bar).
2. Release the parking brake.
3. Fit a torque wrench and turn the set hexagon anticlockwise.
4. If a tightening torque of 18 Nm is **not** reached, but the worm shaft turns at a **lower** torque, the brake adjuster should be replaced.

5



## EXPLANATORY NOTES ON THE MAINTENANCE ACTIVITIES

### Inspection and adjustment

95XF series

7. Depress the brake pedal until pressure gauge (1) reads 6 bar and read off the braking pressure of the rear axle on pressure gauge (2).
8. Compare this value with the data in the table attached to the door pillar.
9. The braking pressure can be corrected by moving the rubber socket (2) in relation to the vertical connecting rod; **do not** adjust the length L of the control lever.
10. Also check that there is no significant reduction in output pressure when under maximum load. This is done by removing ball joint (3) and moving the lever towards the maximum load position.

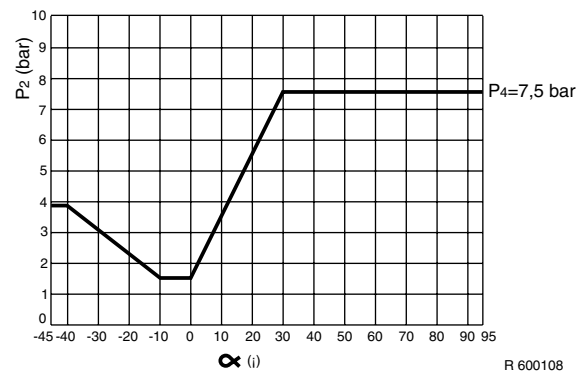
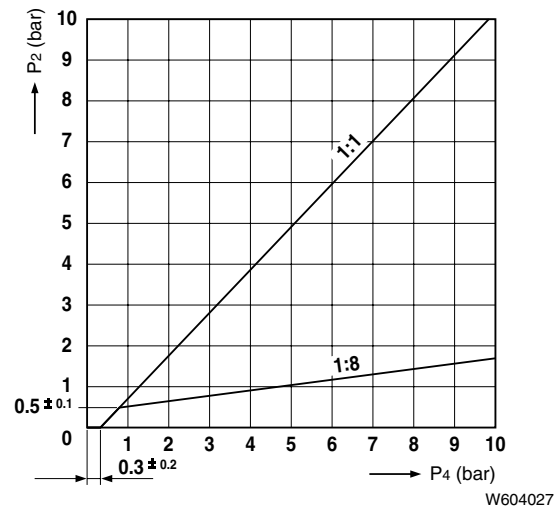

# EXPLANATORY NOTES ON THE MAINTENANCE ACTIVITIES

95XF series

Inspection and adjustment

## 3.26 INSPECTION AND ADJUSTMENT, LOAD-DEPENDENT CONTROL VALVE, AIR SUSPENSION

### Explanatory notes on instruction plate

The information contained on the instruction plate relates to the axle loads, the output pressures and bellows pressures, in accordance with the order of axles beneath the vehicle.

So "1" is the front axle, etc.

To check the load-dependent control valve, the details on the instruction plate relating to the "driven axle" are therefore vital.

L1 = Effective length of unloaded spring between thrust piece and adjustable plug. Spring length in mm.

L2 = bolt length up to counter nut in mm.

1. Check whether the correct valve is fitted (see instruction plate).
2. Connect pressure gauge (4) to the test connection of the load-dependent valve (input pressure).
3. Connect pressure gauge (2) to the test connection on the rear axle brake cylinder (output pressure).
4. Connect pressure gauge (43) with a reducer valve to the simulation connection of the load-dependent valve (simulated adjustable bellows pressure).
5. Make sure that the reservoir pressure is higher than 6.5 bar throughout the measurement.

<b>DAF</b>		1263639																																																				
TYPE - TIPO : FA																																																						
AUTOM. LASTAFHANKELIJE REMKRACHTREGELING AUTOM. LOAD SENSING DEVICE AUTOM. LASTABHANGIGE BREMSKRAFT REGELINR. DISPOSITIF DE CORRECTION AUTOM DE FREINAGE REGOLATORE AUTOM. DELLA FORZA FRENANTE REGULADOR AUTOM. DEL ESFUERZO DE FRENADA																																																						
W 4752711 071 0 p1 = 6.5 bar p4 = 6.0 bar p3 p2 p1 p4 p3		L1 = 114.0 MM L2 = 4.0 MM MIENREGELVENTIL EMPT-Y-LOAD VALVE LAST-LEERVENTIL LAST-LEERVENTIL VALVOLA CARICO-CARICO VALVOLA VIDA/CARGA I = 1: 1,5																																																				
<table border="1"> <tr> <th colspan="2">x 10<sup>4</sup>N</th> </tr> <tr> <td>1</td> <td>2</td> </tr> <tr> <td>2.0</td> <td>2.0</td> </tr> <tr> <td>2.0</td> <td>3.0</td> </tr> <tr> <td>3.0</td> <td>4.0</td> </tr> <tr> <td>4.0</td> <td>10.0</td> </tr> <tr> <td>11.5</td> <td>12.0</td> </tr> <tr> <td>13.0</td> <td></td> </tr> </table>	x 10 <sup>4</sup> N		1	2	2.0	2.0	2.0	3.0	3.0	4.0	4.0	10.0	11.5	12.0	13.0		<table border="1"> <tr> <th colspan="2">URSTURTURE DRUCK</th> </tr> <tr> <td>1</td> <td>2</td> </tr> <tr> <td>4.3</td> <td>1.4</td> </tr> <tr> <td>4.4</td> <td>1.6</td> </tr> <tr> <td>4.4</td> <td>1.6</td> </tr> <tr> <td>4.5</td> <td>2.0</td> </tr> <tr> <td>5.8</td> <td>4.6</td> </tr> <tr> <td>5.9</td> <td>5.3</td> </tr> <tr> <td>5.9</td> <td>5.5</td> </tr> <tr> <td>6.0</td> <td>5.9</td> </tr> </table>	URSTURTURE DRUCK		1	2	4.3	1.4	4.4	1.6	4.4	1.6	4.5	2.0	5.8	4.6	5.9	5.3	5.9	5.5	6.0	5.9	<table border="1"> <tr> <th colspan="2">BAL COILIK</th> </tr> <tr> <td>1</td> <td>2</td> </tr> <tr> <td>0.3</td> <td>0.3</td> </tr> <tr> <td>0.2</td> <td>0.7</td> </tr> <tr> <td>1.2</td> <td>4.1</td> </tr> <tr> <td>4.1</td> <td>4.8</td> </tr> <tr> <td>5.1</td> <td>5.1</td> </tr> <tr> <td>5.6</td> <td></td> </tr> </table>	BAL COILIK		1	2	0.3	0.3	0.2	0.7	1.2	4.1	4.1	4.8	5.1	5.1	5.6	
x 10 <sup>4</sup> N																																																						
1	2																																																					
2.0	2.0																																																					
2.0	3.0																																																					
3.0	4.0																																																					
4.0	10.0																																																					
11.5	12.0																																																					
13.0																																																						
URSTURTURE DRUCK																																																						
1	2																																																					
4.3	1.4																																																					
4.4	1.6																																																					
4.4	1.6																																																					
4.5	2.0																																																					
5.8	4.6																																																					
5.9	5.3																																																					
5.9	5.5																																																					
6.0	5.9																																																					
BAL COILIK																																																						
1	2																																																					
0.3	0.3																																																					
0.2	0.7																																																					
1.2	4.1																																																					
4.1	4.8																																																					
5.1	5.1																																																					
5.6																																																						
<table border="1"> <tr> <th colspan="2">ASL/AST</th> </tr> <tr> <td>1</td> <td>2</td> </tr> <tr> <td>2.0</td> <td>2.0</td> </tr> <tr> <td>2.0</td> <td>3.0</td> </tr> <tr> <td>3.0</td> <td>4.0</td> </tr> <tr> <td>4.0</td> <td>10.0</td> </tr> <tr> <td>11.5</td> <td>12.0</td> </tr> <tr> <td>13.0</td> <td></td> </tr> </table>	ASL/AST		1	2	2.0	2.0	2.0	3.0	3.0	4.0	4.0	10.0	11.5	12.0	13.0		<table border="1"> <tr> <th colspan="2">DELIVERY PRESSURE</th> </tr> <tr> <td>1</td> <td>2</td> </tr> <tr> <td>4.3</td> <td>1.4</td> </tr> <tr> <td>4.4</td> <td>1.6</td> </tr> <tr> <td>4.4</td> <td>1.6</td> </tr> <tr> <td>4.5</td> <td>2.0</td> </tr> <tr> <td>5.8</td> <td>4.6</td> </tr> <tr> <td>5.9</td> <td>5.3</td> </tr> <tr> <td>5.9</td> <td>5.5</td> </tr> <tr> <td>6.0</td> <td>5.9</td> </tr> </table>	DELIVERY PRESSURE		1	2	4.3	1.4	4.4	1.6	4.4	1.6	4.5	2.0	5.8	4.6	5.9	5.3	5.9	5.5	6.0	5.9	<table border="1"> <tr> <th colspan="2">BALL COILIK</th> </tr> <tr> <td>1</td> <td>2</td> </tr> <tr> <td>0.3</td> <td>0.3</td> </tr> <tr> <td>0.2</td> <td>0.7</td> </tr> <tr> <td>1.2</td> <td>4.1</td> </tr> <tr> <td>4.1</td> <td>4.8</td> </tr> <tr> <td>5.1</td> <td>5.1</td> </tr> <tr> <td>5.6</td> <td></td> </tr> </table>	BALL COILIK		1	2	0.3	0.3	0.2	0.7	1.2	4.1	4.1	4.8	5.1	5.1	5.6	
ASL/AST																																																						
1	2																																																					
2.0	2.0																																																					
2.0	3.0																																																					
3.0	4.0																																																					
4.0	10.0																																																					
11.5	12.0																																																					
13.0																																																						
DELIVERY PRESSURE																																																						
1	2																																																					
4.3	1.4																																																					
4.4	1.6																																																					
4.4	1.6																																																					
4.5	2.0																																																					
5.8	4.6																																																					
5.9	5.3																																																					
5.9	5.5																																																					
6.0	5.9																																																					
BALL COILIK																																																						
1	2																																																					
0.3	0.3																																																					
0.2	0.7																																																					
1.2	4.1																																																					
4.1	4.8																																																					
5.1	5.1																																																					
5.6																																																						

M6046

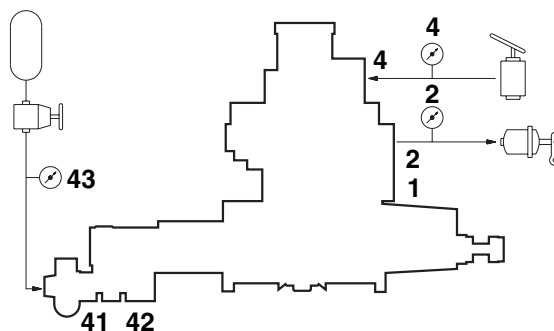

M6102

# EXPLANATORY NOTES ON THE MAINTENANCE ACTIVITIES

## Inspection and adjustment

95XF series

6. Set the simulated bellows pressure at its highest value, as indicated on the instruction plate. Depress the brake pedal until pressure gauge (4) indicates a pressure of 6 bar.  
Read off pressure gauge (2) and check whether this braking pressure matches the pressure shown in the table on the instruction plate.  
If the measured value is incorrect, the value of L2 should be altered.  
Before attempting to change L2, first make all connections pressureless.
  - braking pressure too high: shorten L2
  - braking pressure too low: extend L2

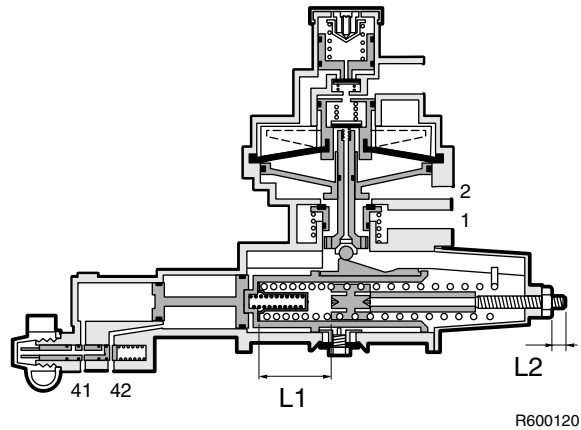

7. Repeat the procedure described in point 6 until the measured brake pressure reading is within the tolerance limits.
8. Set the simulated bellows pressure to its second lowest value, as indicated on the instruction plate. Depress the brake pedal until pressure gauge (4) indicates a pressure of 6 bar.  
Read off pressure gauge 2 and check whether this brake pressure matches the pressure indicated in the table on the instruction plate.  
If the measured value is incorrect, the value of L1 should be altered. This is possible without removing the spring.  
Insert a Philips screwdriver of sufficient length into the hollow adjusting screw.  
Before attempting to change L1, first make all connections pressureless.
  - braking pressure too high: extend L1
  - braking pressure too low: shorten L1
9. If L1 has been changed, repeat the procedure from point 6.

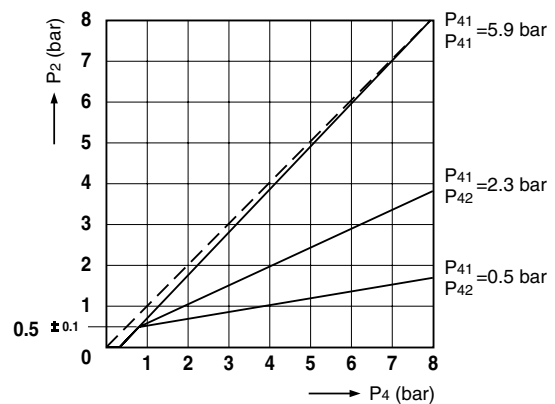

5



## EXPLANATORY NOTES ON THE MAINTENANCE ACTIVITIES

95XF series

Inspection and adjustment

### 3.27 CHECKING THE ELECTROPNEUMATIC VALVES OF ABS/ASR

1. Ensure there is an adequate air supply.
2. Connect a pressure gauge to the brake cylinder of the wheels to be tested.
3. Fully depress the brake pedal. The pressure in the brake cylinder will increase proportionally to the force exerted on the brake pedal.

**Note:**

Remember the influence of the ALR valve.

4. No air should leak at the vent of the electropneumatic valves of the ABS system.
5. Release the brake pedal.
6. Connect DAVIE to the vehicle.
7. Fully depress the brake pedal.
8. Activate the electropneumatic valves of the ABS using DAVIE and check their reaction using the pressure gauge.
9. Release the brake pedal.
10. Activate the electropneumatic valve of the ASR using DAVIE and check its reaction using the pressure gauge.
11. Remove the pressure gauges and DAVIE.

## EXPLANATORY NOTES ON THE MAINTENANCE ACTIVITIES

Inspection and adjustment

95XF series

### 3.28 CHECKING THE COMPRESSOR LINE



Remain at a safe distance from rotating and/or moving components.

**Note:**

When measuring excessive values, the inside of the air dryer housing and the silencer on the exhaust should first be cleaned. Then repeat the check.

1. Bring the engine up to operating temperature.
2. Blow off the brake system to a pressure below the cut-in pressure of the pressure switch.
3. Remove the compressor control pipe (1), which is connected at connection 23 of the air dryer. Then plug the opening at connection 23.
4. Build up pressure in the brake system (pressure switch should cut out).
5. When the engine is not running, remove the safety valve from the compressor line and replace it with a test nipple.
6. Connect a pressure gauge (measuring range 0-16 bar) to the test nipple.
7. Start the engine and run it at maximum speed.
8. The pressure gauge should indicate a pressure below 2 bar **with the governor switched off**. If the pressure reading exceeds the specified value, the line between compressor and air dryer should be replaced.

**Note:**

If the pressure reading is too high, there is excessive carbon deposit in the compressor line. This may be caused by a poor condition of the compressor (oil consumption).

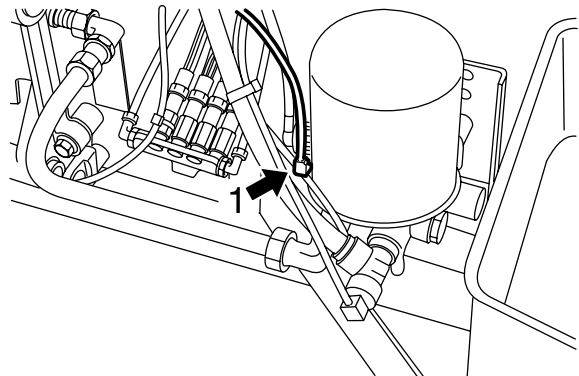

R600250

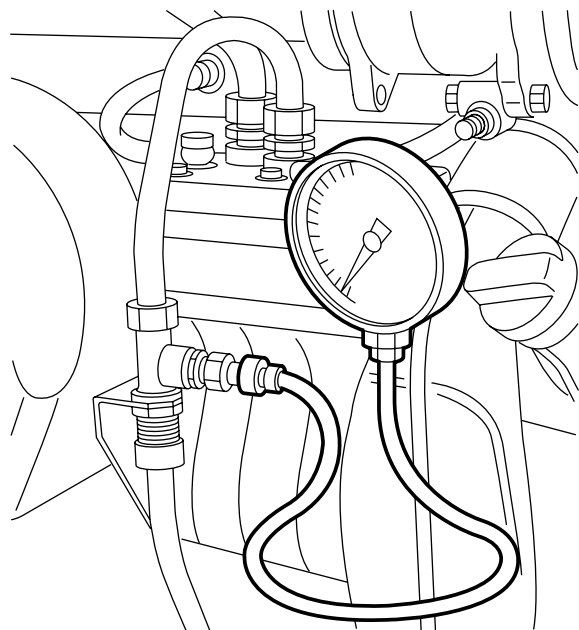

R600249

## EXPLANATORY NOTES ON THE MAINTENANCE ACTIVITIES

**95XF** series

Inspection and adjustment

9. Run the engine at idling speed.
10. Blow off the brake system until the cut-in pressure of the pressure regulator is reached and switch off the engine. The indicator on the pressure gauge should not drop rapidly. If necessary, check the system for leaks. Pay particular attention to the compressor line and compressor.
11. Fit the safety valve.
12. Fit the compressor control pipe to connection 23 of the air dryer.

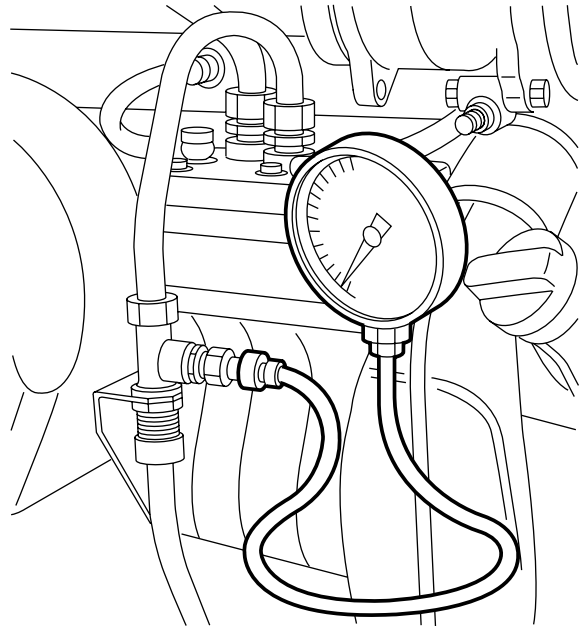

R600249

**5**

## EXPLANATORY NOTES ON THE MAINTENANCE ACTIVITIES

Inspection and adjustment

95XF series

### 3.29 CHECKING THE ATTACHMENT OF THE UNIVERSAL JOINT OF THE STEERING BOX INPUT SHAFT

#### Checking the attachment of the universal joint of the steering box input shaft

1. Check the universal joint for noticeable play. If noticeable play is detected, the universal joint needs to be replaced.
2. Check whether there is any noticeable play between the universal joint and the steering box input shaft. If noticeable play is detected, the splines on the universal joint and those on the input shaft need to be checked for wear. If there is some wear, the affected part must be replaced.
3. If there is noticeable play but the parts are not worn, the nut and bolt must be replaced. Tighten the bolt and nut to the specified torque. See "Technical data".

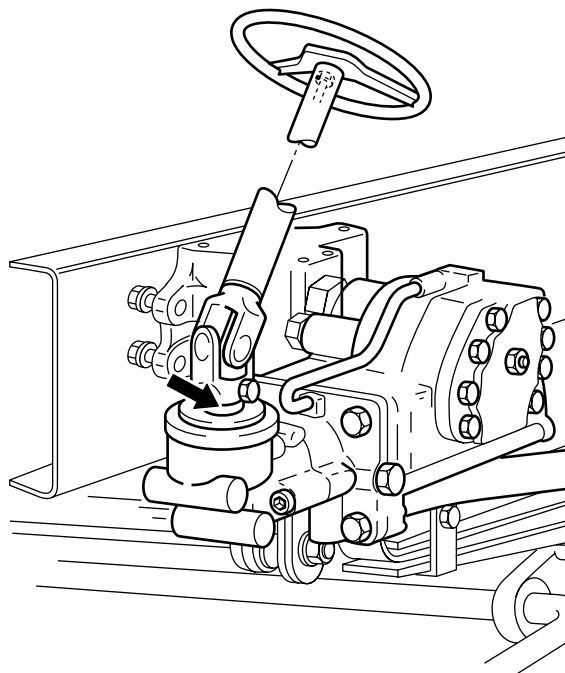

S7 00 639

## EXPLANATORY NOTES ON THE MAINTENANCE ACTIVITIES

95XF series

Inspection and adjustment

### 3.30 CHECKING THE CLUTCH FLUID LEVEL



Hydraulic fluid is toxic and can have a damaging effect on your health. It is therefore important to avoid inhalation and direct contact.

As hydraulic fluid is also a corrosive fluid, it may damage the paintwork of the vehicle. Avoid any contact between hydraulic fluid and paintwork.

Always use new and clean hydraulic fluid which has been kept in a sealed container that meets the specifications. Hydraulic fluid which has absorbed water (from the ambient air) may have an adverse effect on the operation of hydraulic systems.

1. Check whether the fluid level is between the A and B marks when the cab is in the driving position.
2. Mark (C) applies to fully tilted cabs.

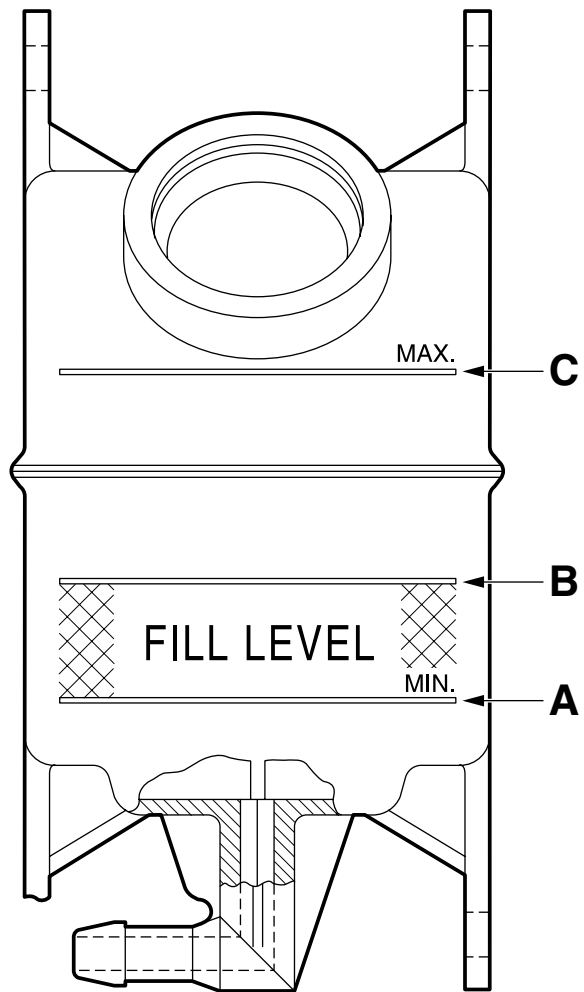

V300178

5

## EXPLANATORY NOTES ON THE MAINTENANCE ACTIVITIES

Inspection and adjustment

95XF series

### 3.31 CHECKING THE HGS FLUID LEVEL



Hydraulic fluid is toxic and can have a damaging effect on your health. It is therefore important to avoid inhalation and direct contact.

As hydraulic fluid is also a corrosive fluid, it may damage the paintwork of the vehicle. Avoid any contact between hydraulic fluid and paintwork.

Always use new and clean hydraulic fluid which has been kept in a sealed container that meets the specifications. Hydraulic fluid which has absorbed water (from the ambient air) may have an adverse effect on the operation of hydraulic systems.

When topping up oil, avoid coming into contact with mineral oil (clean hands, clean funnel etc.).

Mineral oil will damage the seals in the system.

1. Check whether the fluid level is between the upper and lower marks when the cab is tilted back.

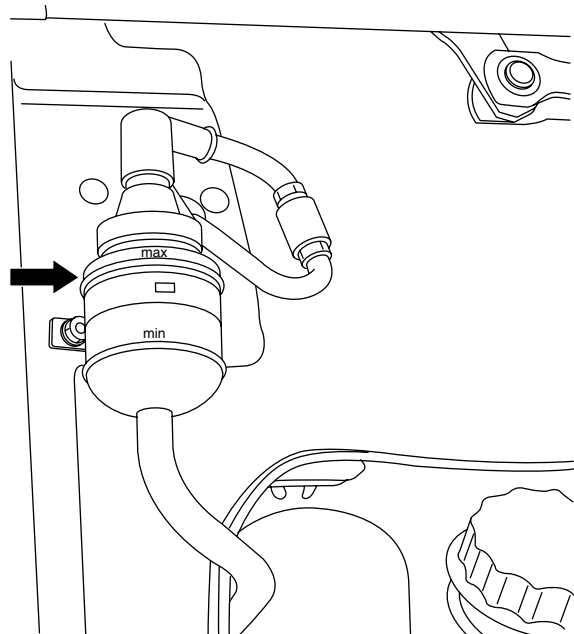

V300100

## EXPLANATORY NOTES ON THE MAINTENANCE ACTIVITIES

95XF series

Inspection and adjustment

### 3.32 CHECKING THE OIL AND GREASE LUBRICATED HUBS FOR LEAKS

If leaks occur in oiled wheel hubs, the wheel hub should be refilled to the correct level – once the leak has been repaired – see “Draining and filling”.

If leaks occur in greased wheel hubs, the bearing grease should be checked. If necessary, the grease should be replaced by grease of the correct specification -once the leak has been repaired-, see specification manual “Fluids and lubricants”.

### 3.33 CHECKING THE DIFFERENTIAL FOR LEAKS

1. Visually inspect the differential for leaks.

### 3.34 CHECKING THE GEARBOX FOR LEAKS

1. Visually check the gearbox for leaks.

### 3.35 CHECKING THE RETARDER FOR LEAKS

1. Visually inspect the retarder for leaks.

### 3.36 CHECKING THE OIL LEVEL OF THE CENTRAL AXLE OF THE TANDEM UNIT

1. Remove the level check/filler plug.
2. The oil level must reach the rim of the level check/filling opening.

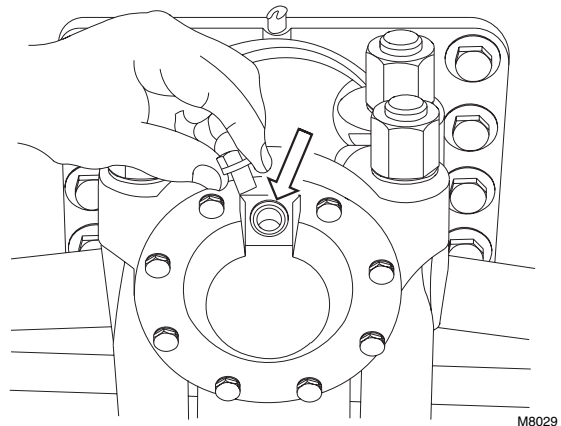

## EXPLANATORY NOTES ON THE MAINTENANCE ACTIVITIES

Inspection and adjustment

95XF series

### 3.37 CHECKING THE OPERATION OF THE DIFFERENTIAL LOCK

1. Jack up the rear axle and support it on stands.
2. Bring the air system to operating pressure.
3. Engage the differential lock. The warning lamp should now come on.
4. Check whether there is a "rigid" connection between the driven wheels.
5. Disengage the differential lock. The warning lamp should not light up and the "rigid" connection between the driven wheels should be broken.

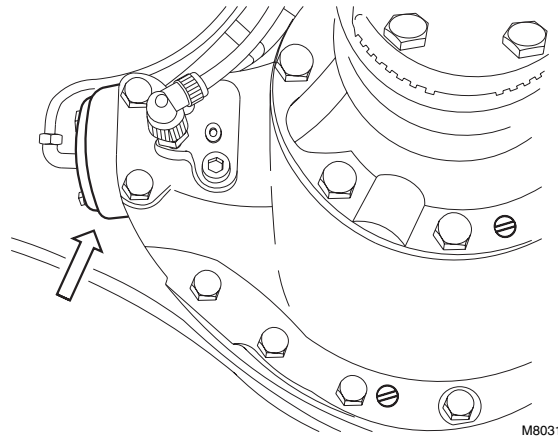

### 3.38 CHECKING THE FLUID LEVEL IN THE HYDRAULIC LIFTING GEAR

1. Make sure that the trailing axle wheels are fully lowered and on the ground.
2. Check the fluid level. The fluid level must be between the "min." and "max." level marks. If necessary, top up.

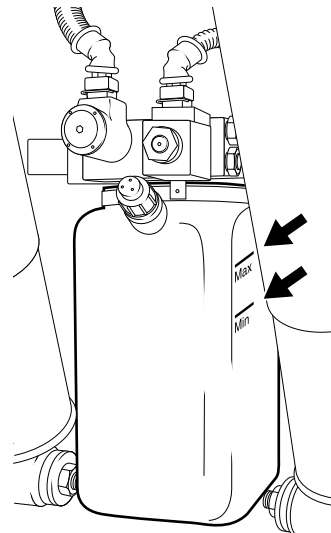

5



## EXPLANATORY NOTES ON THE MAINTENANCE ACTIVITIES

**95XF** series

Inspection and adjustment

### 3.39 CHECKING THE PIVOTS OF THE AXLE SUSPENSION, AIR SUSPENSION

#### **Torque rod**

1. Check the attachment of the torque rod and torque rod supports.
2. Check the pivots of the torque rod for wear and play.

#### **Stabiliser bar**

1. Check the attachment of the stabiliser bar and stabiliser bar support.
2. Check the pivots of the stabiliser bar for wear and play.

#### **Ball joint of triangular link**

1. Check the attachment of the ball joints and three-point fixation support.
2. Check the ball joint housing for surface cracks.
3. Check the dust cover for damage.

## EXPLANATORY NOTES ON THE MAINTENANCE ACTIVITIES

Inspection and adjustment

95XF series

### 3.40 CHECKIGN THE DRIVE SHAFT PLAY

1. Check the universal joints and centre bearing for play and damage.

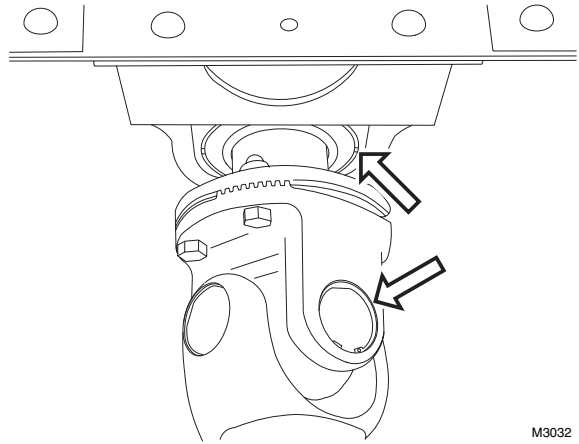

2. Check the sliding clutch for axial and radial play.

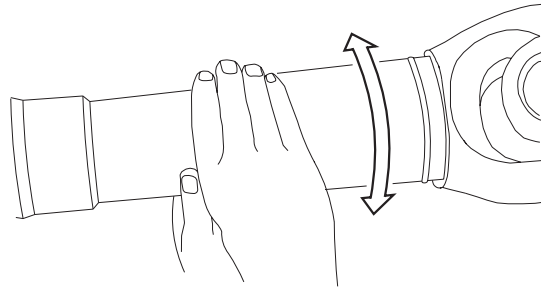

3. There must be no clearly noticeable play on universal joints, centre bearing or sliding clutch.

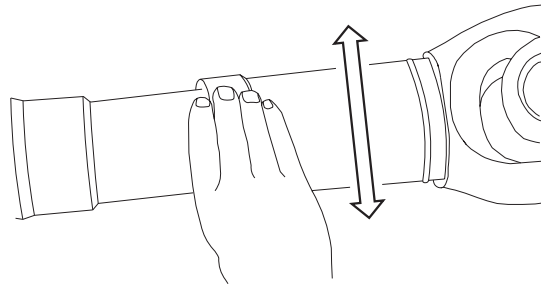

## EXPLANATORY NOTES ON THE MAINTENANCE ACTIVITIES

95XF series

Inspection and adjustment

### 3.41 CHECKING THE AIR SUSPENSION BELLOWS

1. Raise the chassis to its highest position using the remote control.
2. Clean the air bellows using a cleaning rag or a soap solution, if required.
3. Check the air bellows for cracks and damage. If cracks or damage are found through which the webbing is visible, the air bellows should be replaced.
4. Check the air bellows, bellows seating and air line connections for leaks. Check that the air bellows, when in their highest position and in driving position, do not rub against air lines etc.

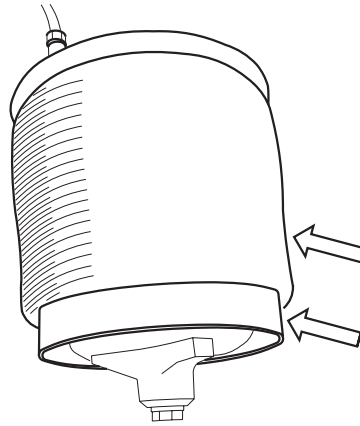

M9040

### 3.42 CHECKING THE OPERATION OF THE AUTOMATIC LUBRICATION SYSTEM

1. Check the system for line fracture and operation of the jets.
2. Check whether all lubricating points are lubricated.
3. Check the lubricant level in the reservoir. If required, top up the reservoir, see chapter "Draining and filling".

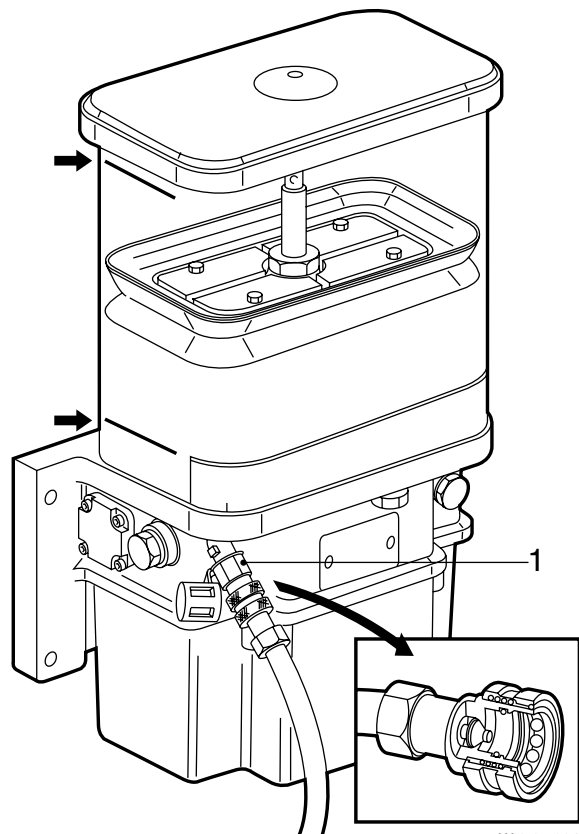

W 9 07 004

5

## EXPLANATORY NOTES ON THE MAINTENANCE ACTIVITIES

Inspection and adjustment

95XF series

### 3.43 CHECKING THE FIFTH WHEEL

1. Check the attachment of the fifth wheel.
2. Check the play of the closing gear of the fifth wheel.

**Note:**

For maximum play values, consult the manufacturer's instructions or the legal requirements.

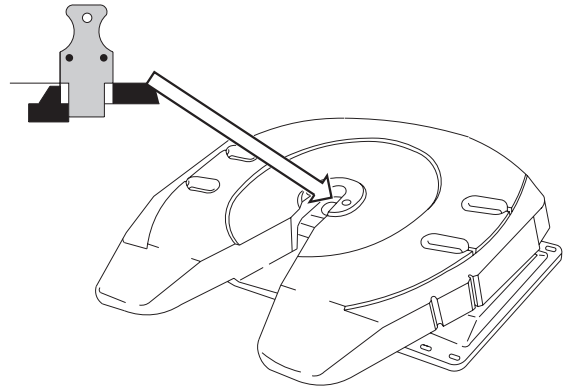

M9003

## EXPLANATORY NOTES ON THE MAINTENANCE ACTIVITIES

95XF series

Inspection and adjustment

### 3.44 CHECKING THE TRAILER COUPLING

1. Check the upward play of the arched pin.
2. Check the radial play of the arched pin.

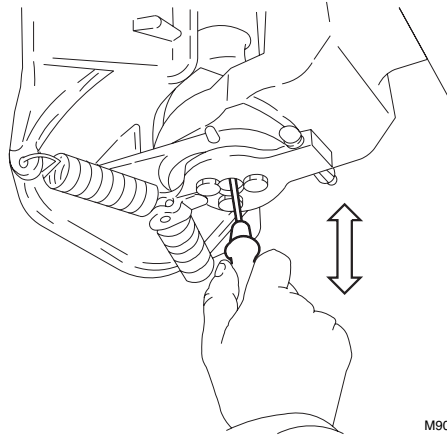

3. Check the vertical and horizontal play of the coupling jaw.

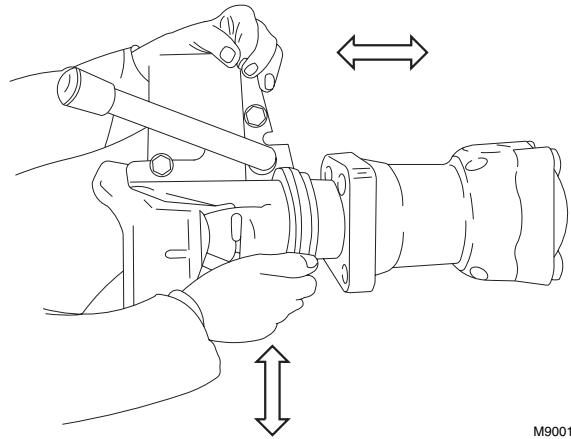

4. Check the diameter of the arched pin.
5. Check the attachment of the trailer coupling and the rear cross member.

**Note:**

For maximum play values, consult the manufacturer's instructions or the legal requirements.

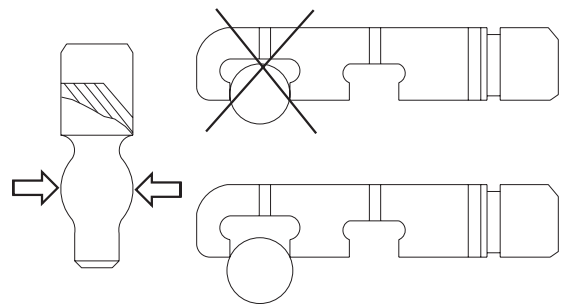

## EXPLANATORY NOTES ON THE MAINTENANCE ACTIVITIES

Inspection and adjustment

95XF series

### 3.45 RETIGHTENING THE HUB NUT OF LEADING REAR AXLE 09N044 (FTP-TYPE VEHICLES)

1. Remove the hub cap (4) using special tool (DAF no. 1329498).
2. Lift the leading rear axle.
3. Release the brakes.
4. Remove the split pin (3) from the hub nut (2).
5. Tighten the lock nut to the specified tightening torque, see "Technical data". Turn the wheel at least 5 revolutions clockwise and then 5 revolutions anti-clockwise while fixing the hub nut.
6. Check that the wheel rotates smoothly.
7. Turn back the hub nut until the split pin can be fitted. Fit a new split pin.

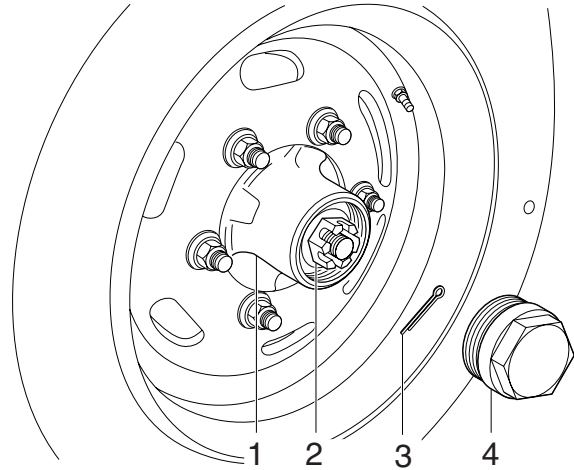

S7 00 657

5

**Note:**

There are 2 split pin holes in the axle journal. Select the split pin hole where the hub nut needs to be turned back least.

8. Fit the hub cap. Tighten the hub cap to the specified torque using the special tool (DAF no. 1329498). See "Technical data".
9. Adjust the brakes.

## EXPLANATORY NOTES ON THE MAINTENANCE ACTIVITIES

95XF series

Inspection and adjustment

### 3.46 INSPECTION AND ADJUSTMENT, WHEEL BEARING PLAY

#### FRONT AXLE/TRAILING AXLE 09N075/LEADING REAR AXLE

##### Checking the wheel bearing play

1. To make sure that the inspection of the wheel bearing play is reliable, use the special tool (DAF no. 0535595).

The special tool consists of:

1. extensions
2. central nut
3. dial gauge holder
4. threaded spindle
5. bridge
6. socket wrench
7. additional extension pieces

2. Remove the hub cap.
3. Remove two opposite wheel nuts.

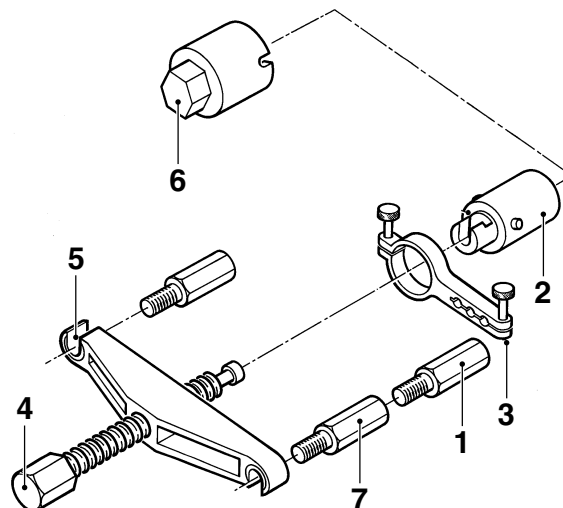

S7 00 131

4. Fit the extensions (1) onto the vacant wheel studs. The extensions belonging to the set should now be extended using the additional extension pieces (7).

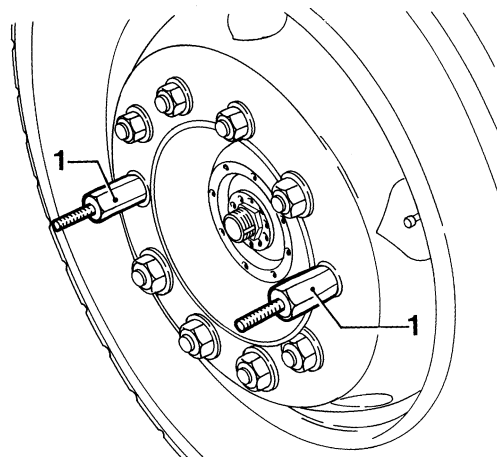

S7 00 079

5. Place the dial gauge holder (3) on the central nut (2).

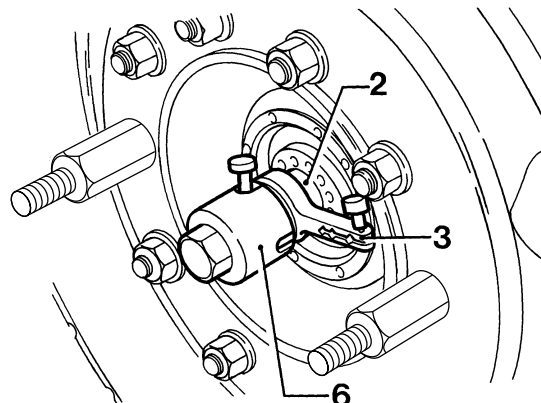

S7 00 080

## EXPLANATORY NOTES ON THE MAINTENANCE ACTIVITIES

### Inspection and adjustment

95XF series

6. Fit the central nut (2) to the axle journal using the socket wrench (6). If the length of screw thread protruding from the lock nut is not enough to fit the central nut (2) to the axle journal, remove the lock nut from the axle journal.

When the axle journal lock nut has been removed, tighten the central nut (2) to the tightening torque specified for the lock nut. See "Technical data".

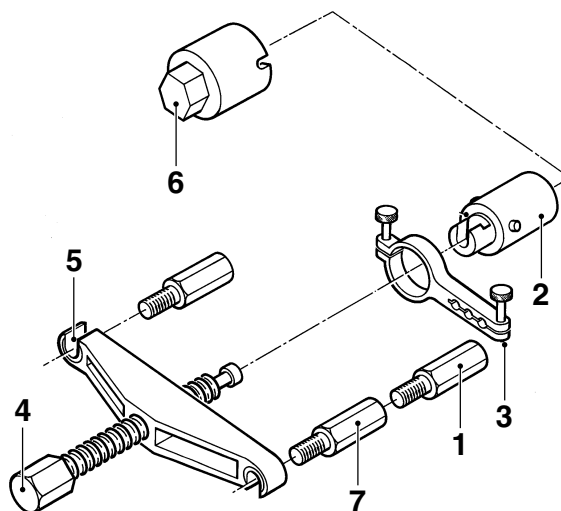

S7 00 131

5

7. Place the dial gauge in the dial gauge holder (3) so that the stylus abuts the hub. Make sure that the stylus of the dial gauge does not enter a threaded hole of the hub, because the stylus might break off when the wheel is turned.

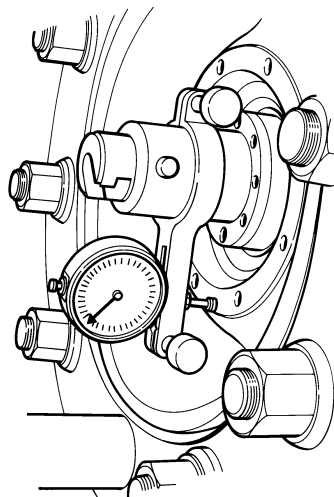

S7 00 081

8. Position the bridge (5) on the extensions (1) so that the end of the spindle fits into the recess of the central nut (2). Tighten the bridge with the nuts.

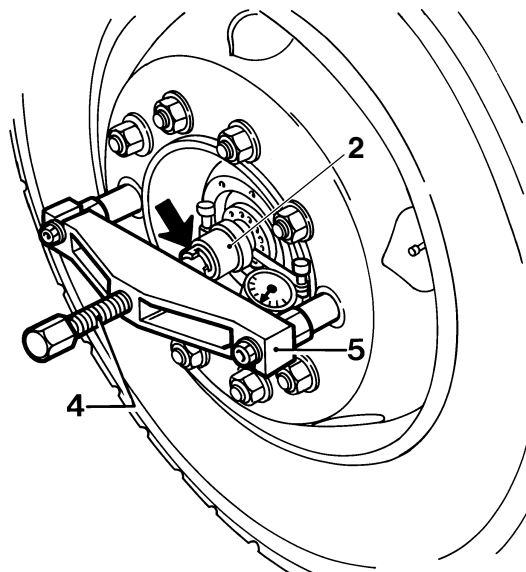

S7 00 082



## EXPLANATORY NOTES ON THE MAINTENANCE ACTIVITIES

95XF series

Inspection and adjustment

9. Place a torque wrench on the hexagon head of the spindle (4). Press the hub firmly onto the axle journal by screwing the spindle in, until a tightening torque of 40 Nm is reached.
10. Withdraw the hub by unscrewing the spindle until a tightening torque of 40 Nm is reached.
11. Press the hub on to the axle journal by screwing the spindle in until a tightening torque of 15 Nm is reached, and set the dial gauge to "0".
12. Withdraw the hub by unscrewing the spindle until a tightening torque of 15 Nm is reached. Take the reading from the dial gauge and compare this value with the specified value, see "Technical data".  
  
If the reading falls outside the tolerance range, the wheel bearing play should be re-adjusted.
13. Remove the special tool.
14. If the lock nut has been removed, the lock plate should be replaced. Tighten the lock nut to the specified tightening torque. See "Technical data".
15. Apply some grease to the outside of the bearing cage.
16. Apply silicone sealant to the hub cap.
17. Install the spring assembly.
18. Tighten the two wheel nuts to the specified tightening torque. See "Technical data". Mark these two nuts and tighten them after 100 km.

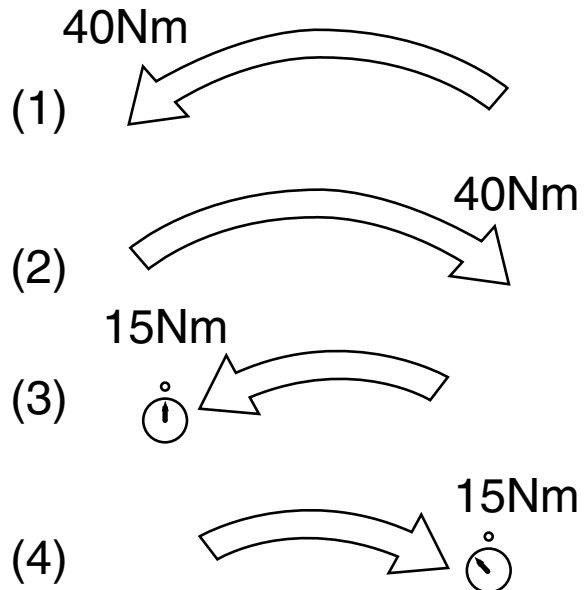

A800150

5

## EXPLANATORY NOTES ON THE MAINTENANCE ACTIVITIES

Inspection and adjustment

95XF series

### Adjusting the wheel bearing play

1. Use a socket wrench (A), special tool (DAF no. 0535832), to remove the lock nut from the axle journal.
2. Remove the lock plate and the circlip from the axle journal.

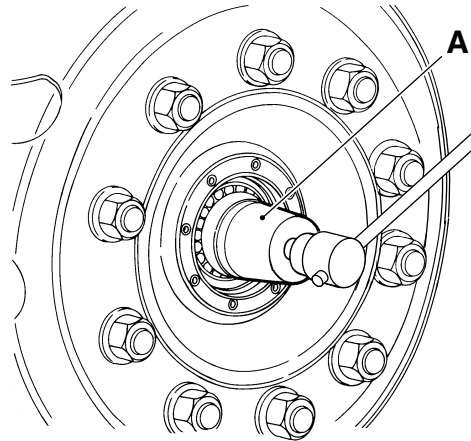

S7 00 084

3. Use an adjusting spanner (A), special tool (DAF no. 0694783), to slacken the adjusting nut (1) one turn.

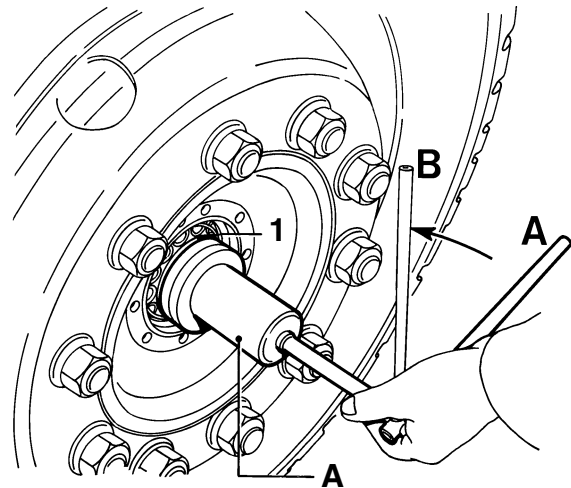

S7 00 085

4. Place a torque wrench on the adjusting spanner. Tighten the adjusting nut to a tightening torque of 100 Nm, while turning the hub.

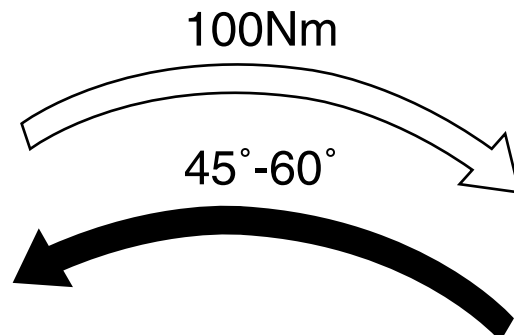

A800138

5

## EXPLANATORY NOTES ON THE MAINTENANCE ACTIVITIES

95XF series

Inspection and adjustment

5. The specified wheel-bearing play is achieved by turning the adjusting nut (1) counter-clockwise between  $45^\circ$  and  $60^\circ$  (distance A - B in the drawing) using the adjusting spanner (A). The precise angle should be such that the circlip (2) can be fitted. If necessary, turn the circlip around, changing the hole pattern.

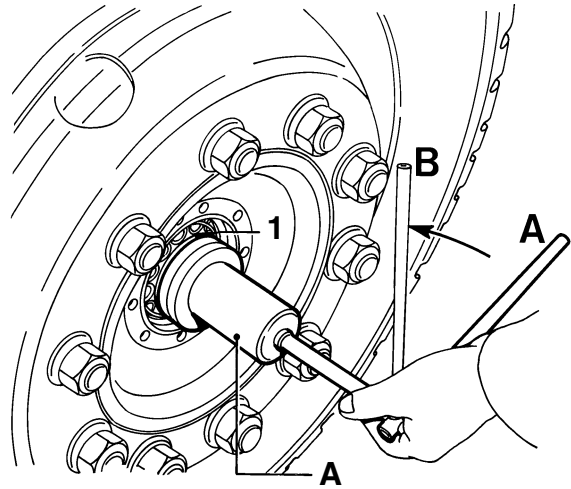

S7 00 085

6. Fit the circlip (2) so that the circlip lip falls into the key groove of the axle journal and the dowel of the adjusting nut (1) falls into one of the holes of the circlip (2).

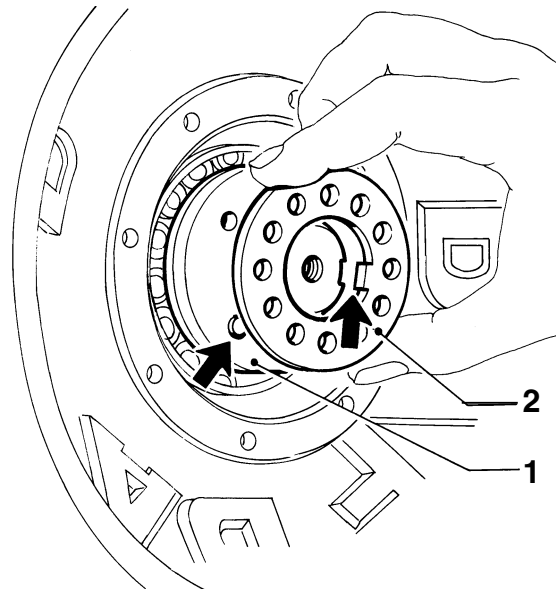

S7 00 086

5

## EXPLANATORY NOTES ON THE MAINTENANCE ACTIVITIES

Inspection and adjustment

95XF series

### LEADING REAR AXLE 09N044 (FTP-TYPE VEHICLES)

#### Checking the wheel bearing play

1. Remove the hub cap using special tool (DAF no. 1329498).
2. Lift the leading rear axle and support it properly.
3. Release the brakes.
4. Fit a dial gauge and let the stylus rest against the axle journal.
5. Push and pull on the wheel. Read the value off the gauge. Compare this reading to the specified value, see "Technical data". If the reading falls outside the tolerance range, the wheel bearing play should be re-adjusted.
6. Fit the hub cap. Tighten the hub cap to the specified torque using the special tool (DAF no. 1329498). See "Technical data".
7. Adjust the brakes.

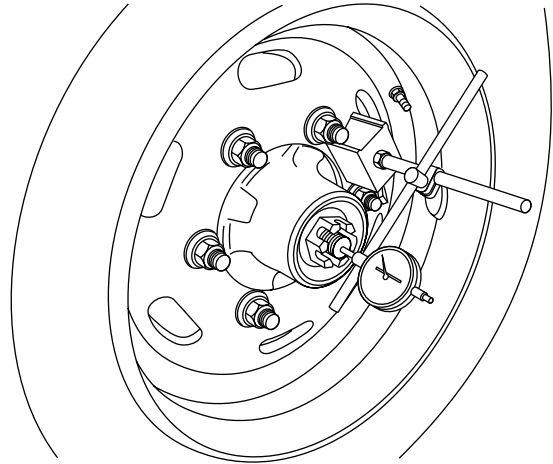

S7 00 635

#### Adjusting the wheel bearing play

1. Remove the hub cap (4) using special tool (DAF no. 1329498).
2. Lift the leading rear axle.
3. Release the brakes.
4. Remove the split pin (3) from the hub nut (2).
5. Tighten the lock nut to the specified tightening torque, see "Technical data". Turn the wheel at least 5 revolutions anti-clockwise and then 5 revolutions clockwise while fixing the hub nut.
6. Check that the wheel rotates smoothly.
7. Turn back the hub nut until the split pin can be fitted. Fit a new split pin.

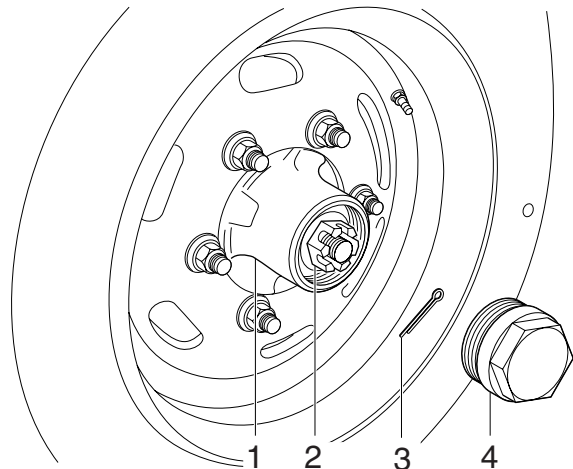

S7 00 657

## EXPLANATORY NOTES ON THE MAINTENANCE ACTIVITIES

95XF series

Inspection and adjustment

**Note:**

There are 2 split pin holes in the axle journal. Select the split pin hole where the hub nut needs to be turned back least.

8. Check the wheel bearing play. Check the bearings for wear if the wheel bearing play is still too large after adjustment.
9. Fit the hub cap. Tighten the hub cap to the specified torque using the special tool (DAF no. 1329498). See "Technical data".
10. Adjust the brakes.

### TRAILING AXLE 09N220

**Checking the wheel bearing play**

1. To make sure that the inspection of the wheel bearing play is reliable, use the special tool (DAF no. 0535595). The special tool consists of:
  1. extensions
  2. central nut
  3. dial gauge holder
  4. threaded spindle
  5. bridge
  6. socket wrench
  7. additional extension pieces
2. Remove the hub cap.
3. Remove two opposite wheel nuts.
4. Fit the extensions (1) onto the vacant wheel studs.
5. Place the dial gauge holder (3) on the central nut (2).

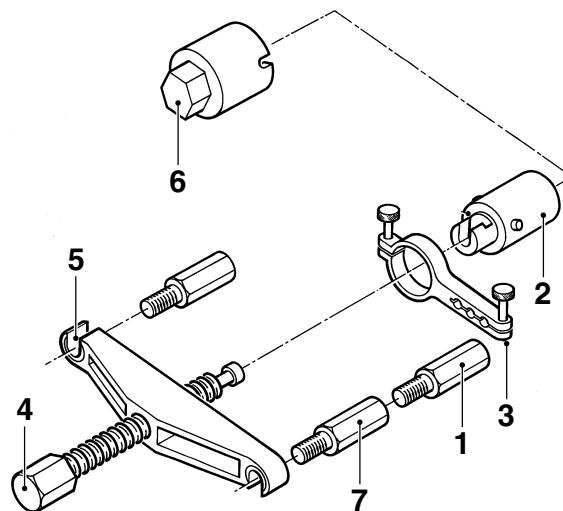

S7 00 131

5

## EXPLANATORY NOTES ON THE MAINTENANCE ACTIVITIES

### Inspection and adjustment

95XF series

6. Fit the central nut (2) to the axle journal using the socket wrench (6).
7. Place the dial gauge in the dial gauge holder (3) so that the stylus abuts the hub. Make sure that the stylus of the dial gauge does not enter a threaded hole of the hub, because the stylus might break off when the wheel is turned.
8. Position the bridge (5) on the extensions (1) so that the end of the spindle fits into the recess of the central nut (2). Tighten the bridge with the nuts.
9. Place a torque wrench on the hexagon head of the spindle (4). Press the hub firmly onto the axle journal by screwing the spindle in, until a tightening torque of 40 Nm is reached.

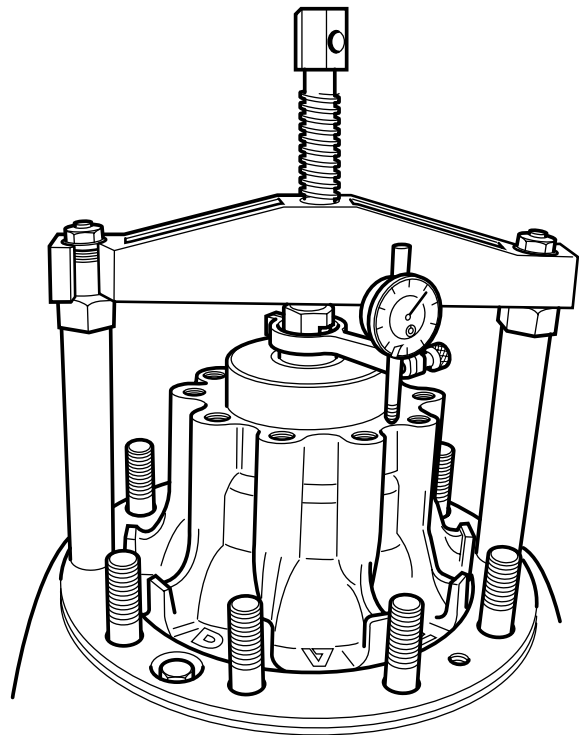

A800149

10. Withdraw the hub by unscrewing the spindle until a tightening torque of 40 Nm is reached.
11. Press the hub on to the axle journal by screwing the spindle in until a tightening torque of 15 Nm is reached, and set the dial gauge to "0".
12. Withdraw the hub by unscrewing the spindle until a tightening torque of 15 Nm is reached. Take the reading from the dial gauge and compare this value with the specified value, see "Technical data".

If the reading falls outside the tolerance range, the wheel bearing play should be re-adjusted.

13. Remove the special tool.
14. If the lock nut has been removed, the lock plate should be replaced. Tighten the lock nut to the specified tightening torque. See "Technical data".

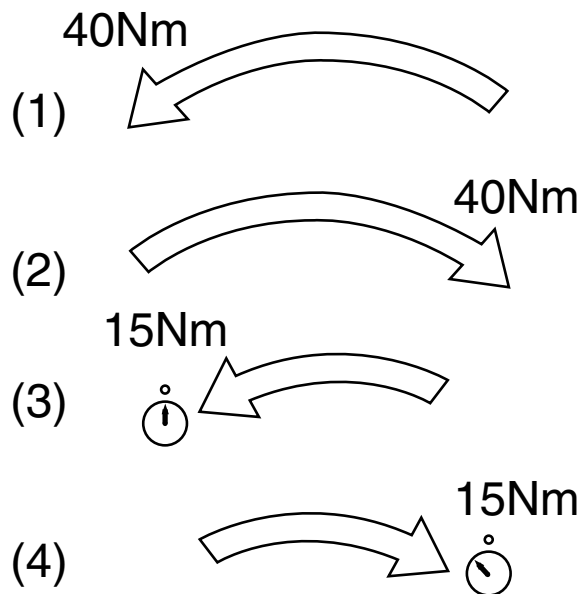

A800150

## EXPLANATORY NOTES ON THE MAINTENANCE ACTIVITIES

95XF series

Inspection and adjustment

15. Apply some grease to the outside of the bearing cage.
16. Apply silicone sealant to the hub cap.
17. Install the spring assembly.
18. Tighten the two wheel nuts to the specified torque. Mark these two nuts and tighten them after 100 km.

### Adjusting the wheel bearing play

1. Use a special tool (DAF no. 0535648) to remove the lock nut from the axle journal.
2. Remove the lock plate and the circlip from the axle journal.
3. Loosen the hub nut one turn.
4. Tighten the adjusting nut to a tightening torque of 100 Nm using a torque wrench, while turning the hub.
5. The specified wheel bearing play is achieved by turning the hub nut counter-clockwise between 45° and 60°. The correct angle is the one that allows the circlip to be fitted. If necessary, turn the circlip around, changing the hole pattern.
6. Fit the circlip so that the circlip lip falls into the key groove of the axle journal and the dowel pin of the axle nut falls into one of the holes of the circlip.
7. Fit the lock nut. Tighten the lock nut to the specified torque using the special tool (DAF no. 0535648). See "Technical data".
8. Install the spring assembly.

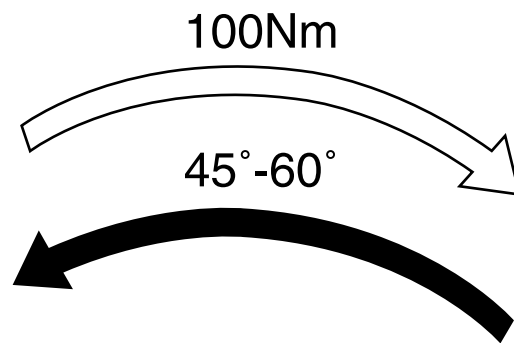
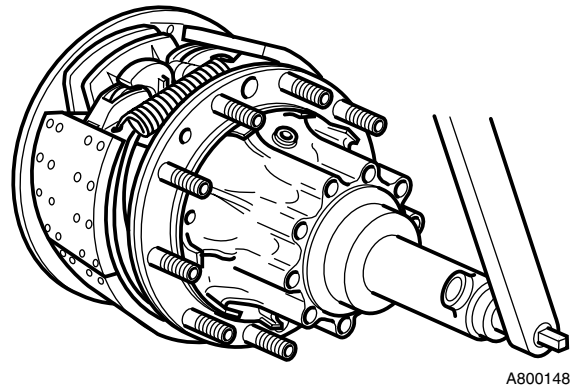

A800148

A800138

5

## EXPLANATORY NOTES ON THE MAINTENANCE ACTIVITIES

Inspection and adjustment

95XF series

### 3.47 CHECKING THE WHEEL HUB AND WHEEL BEARINGS

1. Inspect the bearings for damage at the following points:
  - the roller bearing race,
  - the bearing cage,
  - the raceways of the inner and outer race.

If damage is found, the entire bearing (inner race/bearing cage and outer race) should be replaced.

2. When the outer race of the bearing is loose in the hub or has turned in the hub, the hub should be replaced.
3. The following points of the axle journal should be inspected for damage: the screw thread, the bearing surfaces of the inner bearing races and the running surface of the seal.
4. Check the sensor ring for damage. If even the slightest damage is found on this ring, it should be replaced.

5

### 3.48 CHECKING THE SUPERSTRUCTURE ATTACHMENT

1. Check that all attachment bolts are present.
2. Visually check the attachment of the superstructure for faults.

### 3.49 CHECKING THE ATTACHMENT AND CONDITION OF SPRING LEAVES, SPRING CLAMPS AND U-BOLTS

1. Visually inspect the condition and attachment of the U-bolts.
2. When retightening the U-bolt nuts, the attachment nut **must not be slackened first** and then tightened to a specific torque, see "Technical data".



## EXPLANATORY NOTES ON THE MAINTENANCE ACTIVITIES

95XF series

Removal and installation

### 4. REMOVAL AND INSTALLATION

#### 4.1 REMOVAL AND INSTALLATION, INTERIOR FILTER ELEMENT

##### Removing the interior filter element

1. Open the grille.
2. Remove the attachment bolts (1) at the bottom of the filter.
3. Remove the filter (2).
4. If required, clean the filter, see chapter "Cleaning".  
In case of excessive fouling or damage, the filter should be replaced.

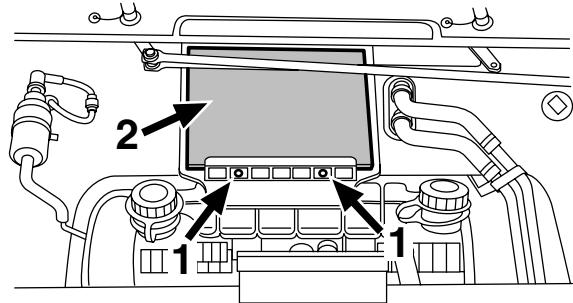

K100355

##### Installing the interior filter element

1. Fit the filter (2) in the correct position.  
The arrows on the filter indicate the air flow direction.
2. Insert the attachment bolts (1).

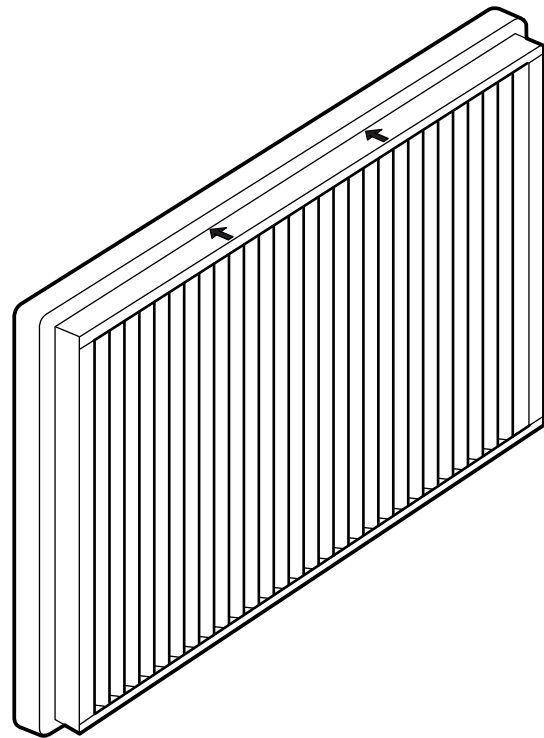

K100386

## EXPLANATORY NOTES ON THE MAINTENANCE ACTIVITIES

Removal and installation

95XF series

### 4.2 REMOVAL AND INSTALLATION, OIL FILTER



To prevent skin injury, avoid unnecessary contact with the drained oil.

XF/XE engine

#### Removing the oil filter

1. Place a tray beneath the filter.
2. Remove the filter by turning it counter-clockwise using a strap wrench.

**Note:**

The oil filter is a disposable filter, and may not be cleaned and reused.

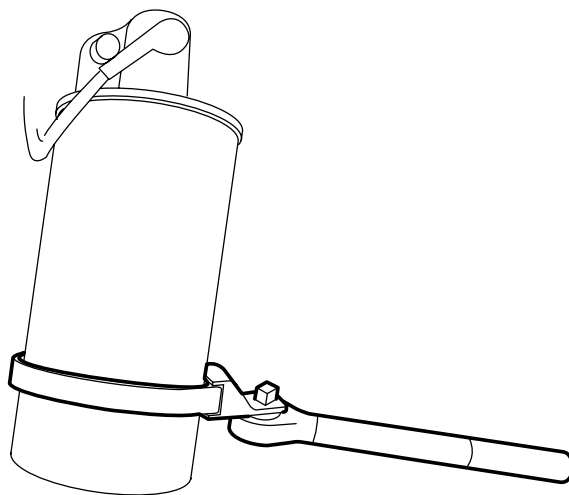

M200370

#### Installing the oil filter

1. Fill the new oil filter before fitting using the specified oil grade.
2. Lightly lubricate the sealing ring with engine oil.
3. Fit the filter so that the seal makes contact. Then tighten the filter to the specified tightening torque, see "Technical data".
4. Start the engine, and run it at idling speed for a short time. Check whether the oil filter is correctly sealed.
5. Then check the oil level.

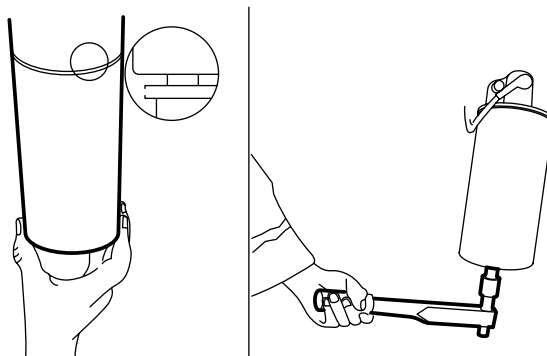

M200371

## EXPLANATORY NOTES ON THE MAINTENANCE ACTIVITIES

95XF series

Removal and installation

### VF engine

#### Removing the oil filter

1. Place a tray beneath the filter.
2. Remove the filter by turning it counter-clockwise using special tool (DAF no. 1240115).

**Note:**

The oil filter is a disposable filter, and may not be cleaned and reused.

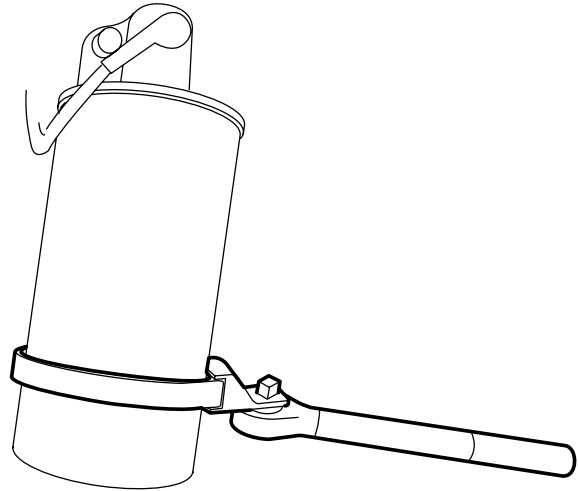

M200370

#### Installing the oil filter

1. Fill the new oil filter before fitting using the specified oil grade.
2. Lightly lubricate the sealing ring with engine oil.
3. Fit the filter so that the seal makes contact. Then tighten the filter to the specified tightening torque, see "Technical data".
4. Start the engine, and run it at idling speed for a short time. Check whether the oil filter is correctly sealed.
5. Then check the oil level.

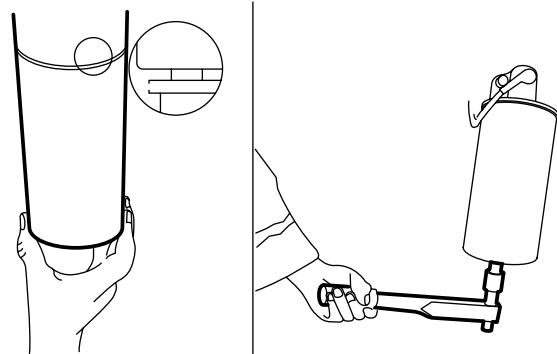

M200371

5

## EXPLANATORY NOTES ON THE MAINTENANCE ACTIVITIES

Removal and installation

95XF series

### 4.3 REMOVAL AND INSTALLATION, CENTRIFUGAL OIL FILTER ROTOR



To prevent skin injury, avoid unnecessary contact with the drained oil.

#### Removing the centrifugal oil filter rotor

1. Clean the housing (3).
2. Loosen the central bolt (4).
3. Remove the housing (3) together with the central bolt (4) and the rotor (2).
4. Remove the rotor (2) from the central bolt (4).
5. Replace the rotor (2).

#### Installing the centrifugal oil filter rotor

1. Clean the housing (3).
2. Check the central bolt (4) for damage.
3. Replace the sealing ring (5).
4. Fit the new rotor into the housing.
5. Lightly oil the seal (5) and fit it in the housing (3).  
Tighten the central bolt (4) to the specified torque. See "Technical data".
6. Start the engine and check for leakage.  
Check the oil level.

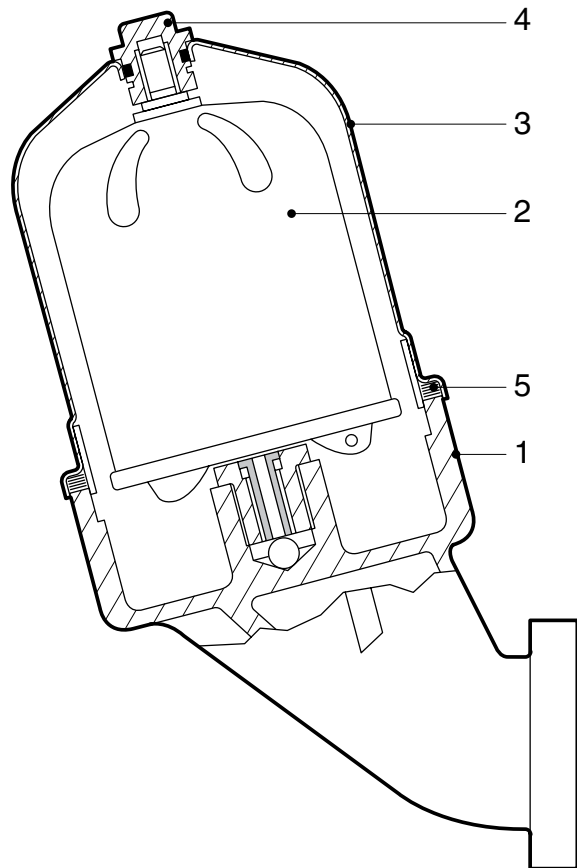

M200526

## EXPLANATORY NOTES ON THE MAINTENANCE ACTIVITIES

95XF series

Removal and installation

### 4.4 REMOVAL AND INSTALLATION, AIR FILTER ELEMENT

#### Removing the air filter element

1. Loosen the retaining clamps (1) on the air filter cover (2).
2. Remove the air filter cover.
3. Remove the air filter element (3).
4. Check the air filter element for damage. If the air filter element or its seals are damaged, the air filter element must be replaced.
5. Clean the inside of the air filter housing and the air filter cover.
6. If required, clean the air filter, see chapter "Cleaning".
7. When replacing the air filter element, reset the air filter indicator, if fitted, by pressing the button on the upper side of the indicator.

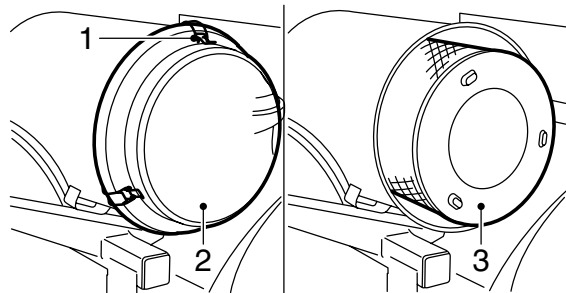

i 400207

#### Installing the air filter element

1. Fit the air filter element in the air filter housing.
2. Fit the air filter cover, making sure the arrow on the cover points upwards.

**Note:**

This position is important if a rubber sealing valve has been installed on the air filter cover.

3. Fit the retaining clamps.
4. Check that the flexible bellows-type sealing cover (5) on the air intake is not damaged. Replace if necessary.

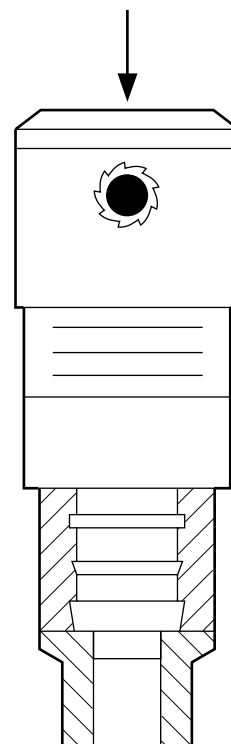

M200729

**Important!**

The filter element can be cleaned once, after which it must be renewed.

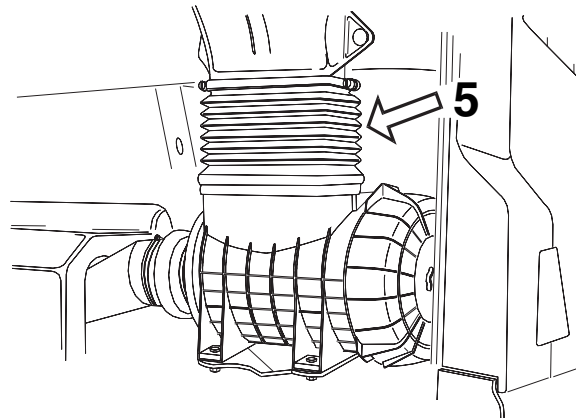

M2116

5

## EXPLANATORY NOTES ON THE MAINTENANCE ACTIVITIES

Removal and installation

95XF series

### 4.5 REMOVAL AND INSTALLATION, FUEL FILTER



When removing the fuel filter, a quantity of fuel will escape. Collect the fuel to avoid the risk of fire.

#### XF/XE engine

##### Removing the fuel filter

1. Place a tray beneath the filter.
2. Remove the filter by turning it counter-clockwise.

##### Note:

The fuel filter is a disposable filter, and must not be cleaned and reused.

##### Installing the fuel filter

1. Do **not** fill the new fuel filter with diesel fuel.
2. Lightly lubricate the sealing ring with engine oil, not with diesel fuel.
3. Fit the filter until the sealing ring abuts, and manually rotate a  $\frac{1}{2}$  to  $\frac{3}{4}$  turn further.

##### Note:

Do not use any tools when tightening.

4. Bleed the fuel system, if necessary. See "Inspection and adjustment".
5. Start the engine and check for leaks. If necessary, tighten the filter.

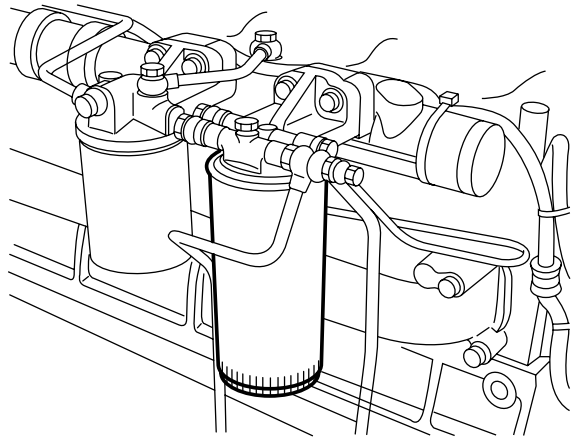

i 400192

## EXPLANATORY NOTES ON THE MAINTENANCE ACTIVITIES

95XF series

Removal and installation

### VF engine

#### Removing the fuel filters

1. Place a tray beneath the filters to capture any escaping fuel.
2. Remove the filters by turning them counter-clockwise.

**Note:**

The fuel filter is a disposable filter, and must not be cleaned and reused.

#### Installing the fuel filters

1. Do **not** fill the new fuel filters with diesel fuel.
2. Lightly lubricate the sealing ring with engine oil or diesel fuel.
3. Install the filters and tighten them by hand.
4. Start the engine and check for leaks. If necessary, tighten the filters.

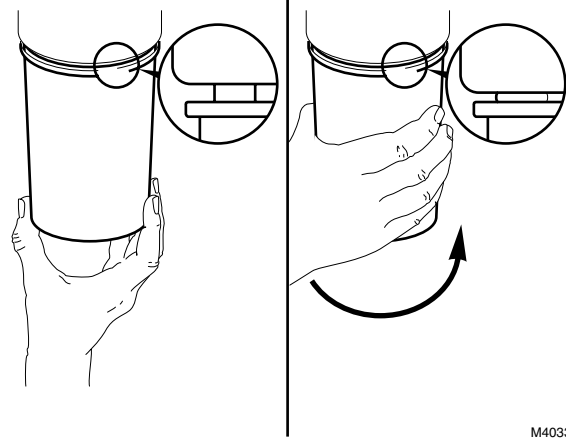

M4033

## EXPLANATORY NOTES ON THE MAINTENANCE ACTIVITIES

Removal and installation

95XF series

### 4.6 REMOVAL AND INSTALLATION, RACOR-FILTER ELEMENT



**When removing the Racor filter element, fuel will escape. Collect the fuel to avoid the risk of fire.**

#### Removing the Racor filter element

1. Drain the fuel from the filter element by unscrewing the bleed plug (2) and opening the drain plug (8).
2. If fitted, disconnect the water sensor (6) and the heating element (7) connectors.
3. Loosen the filter element (4) and the bottom cover (5). Remove the bottom cover and clean the O-ring seal.

#### Installing the Racor filter element

1. Apply a film of engine oil to the O-ring and the new sealing ring. Fit the bottom cover (5) to the new filter element (4), fill the filter with clean diesel fuel and fit the assembly to the filter housing (3).
2. Hand-tighten the new filter.
3. Connect the connector of the water sensor and the heating element (if present).
4. Bleed the fuel system, if necessary. See "Inspection and adjustment".
5. Bleed the filter by operating the hand pump with the bleed nipple (2) opened, until the fuel flows out. Close the bleed nipple.
6. Start the engine and check for leaks. If necessary, tighten the filter.

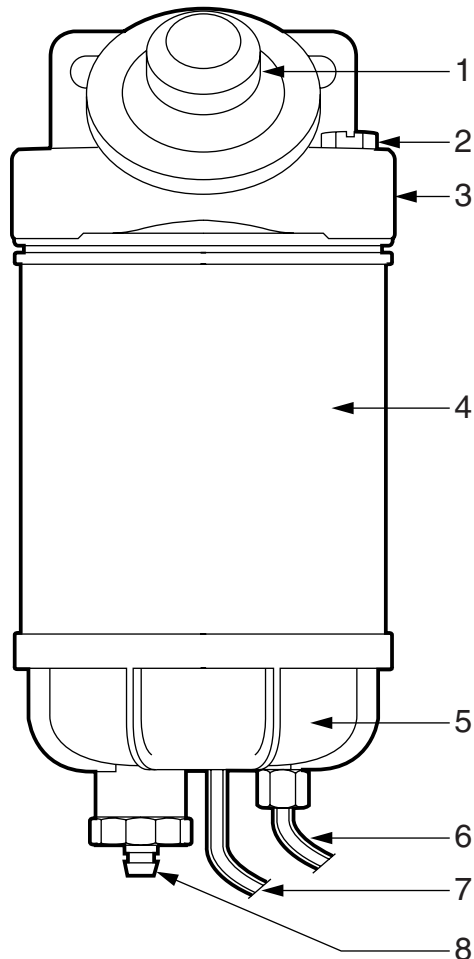

i400356

5



## EXPLANATORY NOTES ON THE MAINTENANCE ACTIVITIES

95XF series

Removal and installation

### 4.7 REMOVAL AND INSTALLATION, FUEL COARSE FILTER



**A quantity of fuel will escape when the fuel coarse filter is removed. Collect the fuel to avoid the risk of fire.**

#### Removing the fuel coarse filter

1. Place a tray beneath the filter.
2. Remove the cover by turning it counter-clockwise.
3. Remove the coarse filter (1).
4. Check the seal (2) for damage. Replace the seal if it is damaged.

#### Installing the fuel coarse filter

1. Apply a thin layer of non-acidic grease to the seal.
2. Install the cover together with the coarse filter by screwing the cover on finger-tight.
3. Bleed the fuel system, if necessary. See "Inspection and adjustment".
4. Start the engine and check for leaks. Retighten the filter by hand, if necessary.

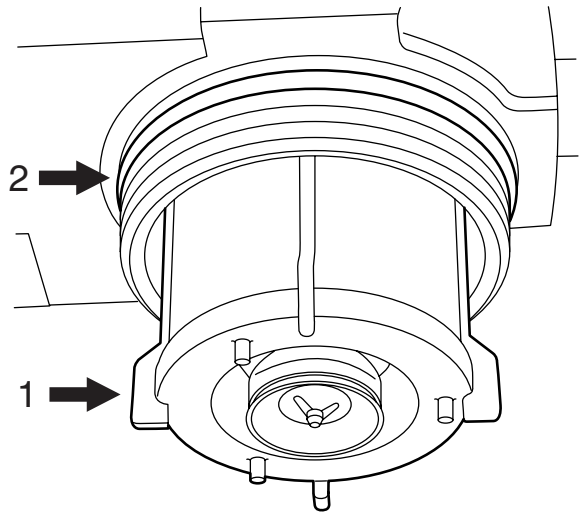

i400384

5

## EXPLANATORY NOTES ON THE MAINTENANCE ACTIVITIES

Removal and installation

95XF series

### 4.8 REMOVAL AND INSTALLATION, COOLANT FILTER



When the coolant is hot, there is an overpressure in the cooling system. Carefully remove the filler cap to release the overpressure.

Coolant is a toxic fluid. Contact with the skin should therefore be avoided.

In order to avoid damaging the cylinder block, do not top up a warm engine with cold coolant.

#### XF/XE engine

##### Removing the coolant filter

1. Place a tray beneath the coolant filter to collect any escaping coolant.
2. Remove the filler cap from the expansion tank.
3. Turn the shut-off valve (1) clockwise to the "C" position.
4. Remove the coolant filter by turning it counter-clockwise.

##### Installing the coolant filter

1. Clean the sealing face of the coolant filter.
2. Apply a small amount of coolant to the seal of the coolant filter element.
3. Fit the coolant filter so that the seal makes contact. Then tighten the filter by hand  $\frac{1}{2}$ - to  $\frac{3}{4}$ -of a turn.
4. Switch shut-off valve (1) counter-clockwise to the "O"-position.
5. Fit the filler cap on the expansion tank.
6. Run the engine and check that the coolant filter has sealed correctly.
7. Check the coolant level.

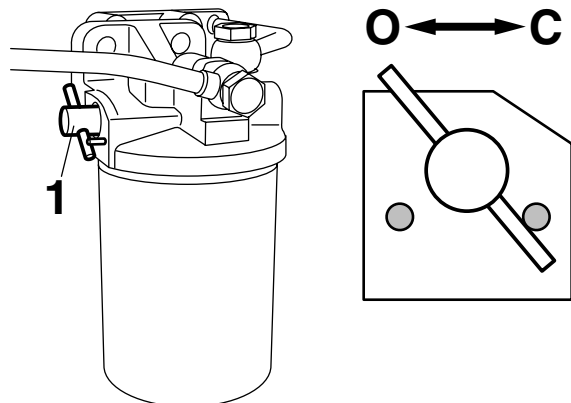

M200372

## EXPLANATORY NOTES ON THE MAINTENANCE ACTIVITIES

95XF series

Removal and installation

### VF engine

#### Removing the coolant filter

1. Place a tray beneath the coolant filter to collect any escaping coolant.
2. Remove the filler cap from the expansion tank.
3. Switch the shut-off valve to the "OFF" position. This is the horizontal position.
4. Remove the coolant filter by turning it counter-clockwise.

#### Installing the coolant filter

1. Clean the sealing face of the coolant filter.
2. Apply a small amount of coolant to the seal of the coolant filter element.
3. Fit the coolant filter so that the seal makes contact. Then tighten the filter by hand  $\frac{1}{2}$ - to  $\frac{3}{4}$ -of a turn.
4. Switch the shut-off valve to the "ON" position. This is the vertical position.
5. Fit the filler cap on the expansion tank.
6. Run the engine and check that the coolant filter has sealed correctly.
7. Check the coolant level.

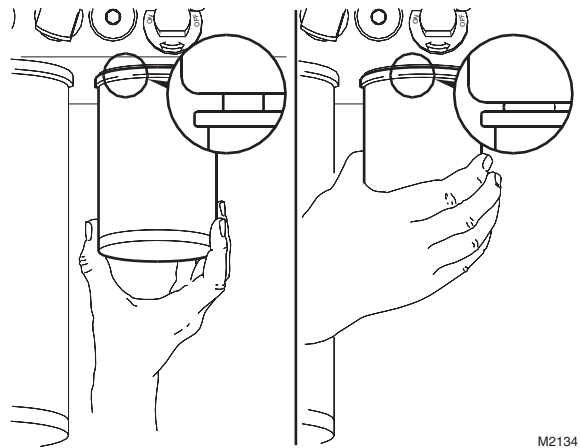
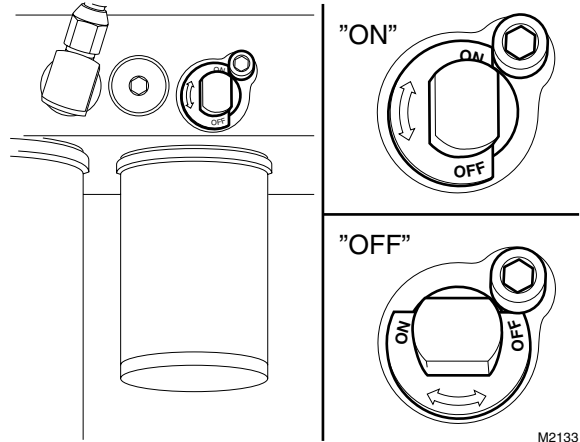

## EXPLANATORY NOTES ON THE MAINTENANCE ACTIVITIES

Removal and installation

95XF series

### 4.9 REMOVAL AND INSTALLATION, V-BELT

XF/XE engine

#### Adjusting the V-belt tension of the water pump and alternator drive

1. Slacken the alternator bracket attachment bolts (1) and (2).
2. Loosen the attachment bolt (3) of the threaded spindle that is fixed to the water pump.
3. Turn the nut (5) of the threaded spindle to tilt the alternator towards the cylinder block.
4. Remove the V-belt(s) through the aperture in the guide ring (see arrow in the illustration). Hang the V-belt over a fan blade. Rotate the fan blade by blade, hanging the V-belt over them. Repeat this for the entire fan, after which the belt can be removed.

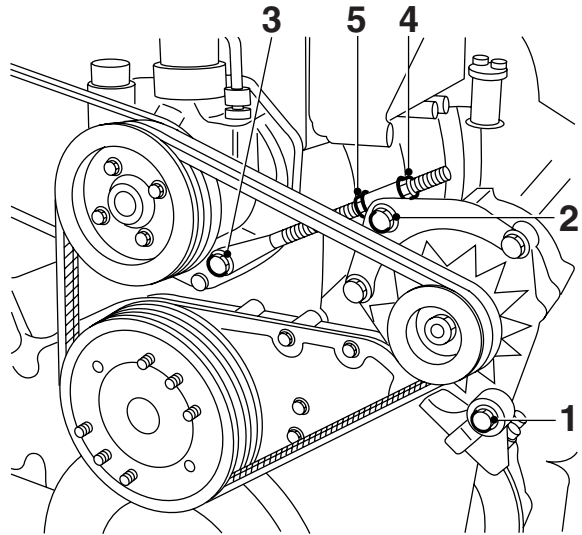

M200550

#### Note:

In engines where the fan ring is fitted to the cylinder block, the fan or the fan ring, depending on the accessibility of the attachment bolts, must be removed before the V-belt can be removed.

#### Installing the V-belt(s) of the water pump and alternator drive

1. Inspect the pulleys for damage, rust and grease deposits.
2. Fit the new V-belts and adjust the V-belt tension. See "Inspection and adjustment".
3. Install the fan if it has been removed.

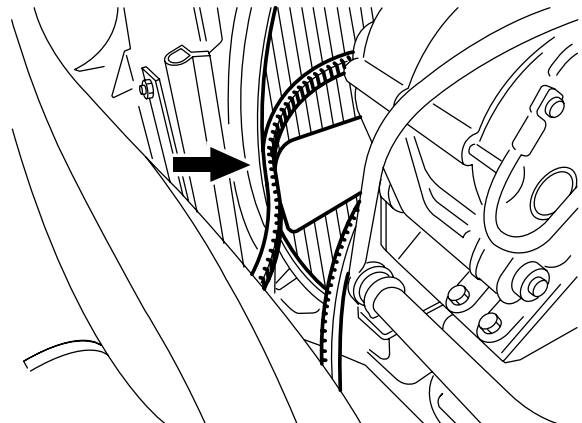

M200558

5

## EXPLANATORY NOTES ON THE MAINTENANCE ACTIVITIES

95XF series

Removal and installation

### Removing the V-belt of the air-conditioning compressor drive

1. Loosen the lower attachment bolt (1) of the alternator.
2. Loosen the upper attachment bolt (2) of the alternator.
3. Loosen the attachment bolt (3) of the threaded spindle that is fixed to the water pump.
4. Turn the locknuts (4) and (5) on the threaded spindle so that the alternator can be tilted towards the cylinder block and the V-belt can be removed from the pulley.
5. Slacken the upper attachment bolt (1) of the compressor.
6. Slacken the lower attachment bolt (2) of the compressor.
7. Loosen the attachment bolt from the threaded spindle which is attached to the water pump.
8. Turn the lock nut (3) on the threaded spindle so that the compressor is tilted towards the cylinder block and the V-belt can be removed.

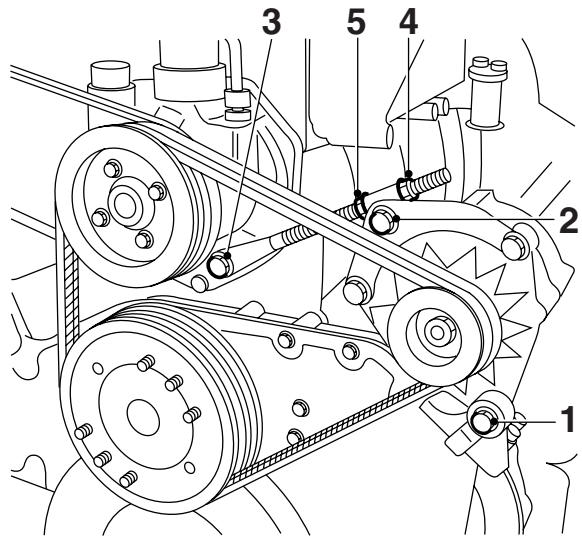

M200550

### Installing the V-belt of the air-conditioning compressor drive

1. Inspect the pulleys for damage, rust and grease deposits.
2. Fit the V-belt for the air-conditioning compressor drive and adjust the V-belt tension. See chapter "Inspection and adjustment".
3. Install the V-belt for the water pump, alternator and fan drive and adjust the V-belt tension, see chapter "Inspection and adjustment".

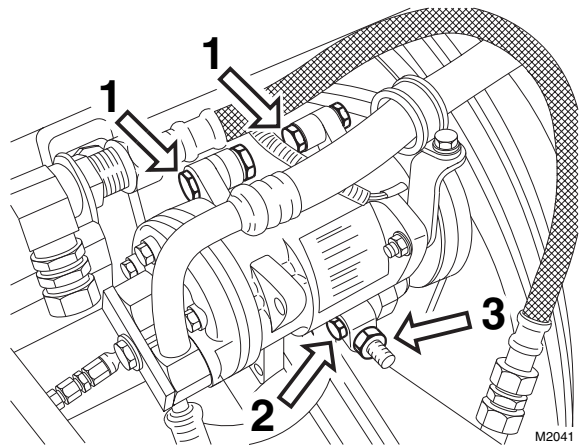

M2041

5

## EXPLANATORY NOTES ON THE MAINTENANCE ACTIVITIES

Removal and installation

95XF series

### VF engine

#### Removing the V-belt of the air-conditioning compressor drive

1. Slacken the attachment bolt (1) in the clamping block (2) and slacken the attachment bolt of the threaded spindle on the cylinder block.
2. Slacken the attachment bolts on the compressor.
3. Turn the lock nuts (3) so that the compressor is tilted towards the cylinder block. Then remove the V-belt.

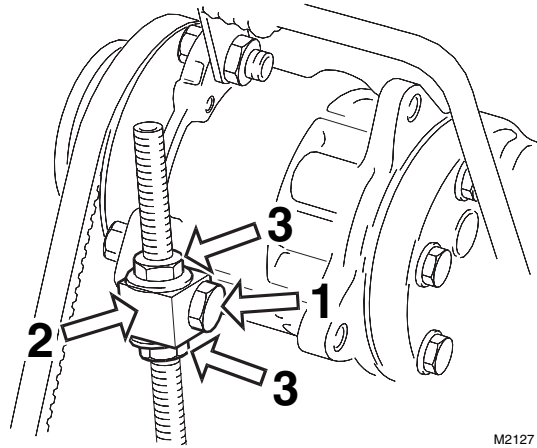

#### Installing the V-belt of the air-conditioning compressor drive

1. Inspect the pulleys for damage, rust and grease deposits.
2. Fit the new V-belt and adjust the V-belt tension, see "Inspection and adjustment".

## EXPLANATORY NOTES ON THE MAINTENANCE ACTIVITIES

95XF series

Removal and installation

### Removing the poly V-belt (10-rib) of fan and alternator drive

1. Slacken the attachment bolt (1) in the clamping block (2) and slacken the attachment bolt of the threaded spindle on the cylinder block.
2. Slacken the attachment bolt (3) in the alternator support.
3. Turn the lock nuts (4) so that the compressor is tilted towards the cylinder block.
4. Remove the belt through the opening at the guide ring.

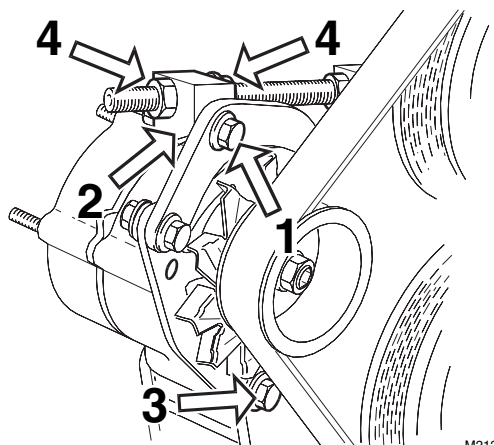

M2128

### Installing the poly V-belt (10-rib) of fan and alternator drive

1. Inspect the pulleys for damage, rust and grease deposits.
2. Fit the new belt through the opening at the guide ring. Adjust the belt tension, see chapter "Inspection and adjustment".

### Removing the poly V-belt (6-rib) of the water pump drive

1. Remove the compressor drive belt.
2. Slacken the central nut (1) of the tensioner.
3. By means of bolt (2) move the tension pulley until the belt can be removed.

### Installing the poly V-belt (6-rib) of the water pump drive

1. Inspect the pulleys for damage, rust and grease deposits.
2. Fit the new belt and adjust the belt tension, see "Inspection and adjustment".

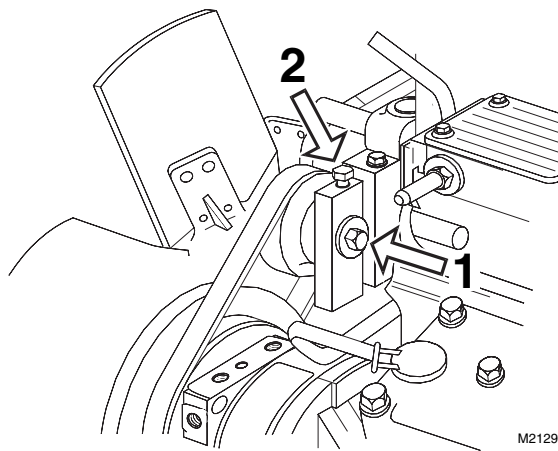

M2129

5

## EXPLANATORY NOTES ON THE MAINTENANCE ACTIVITIES

Removal and installation

95XF series

### 4.10 REMOVAL AND INSTALLATION, C-BRAKE

#### Removing the C-brake

1. Remove the C-brake connectors on the C-brake housing.
2. Remove the C-brake housing attachment bolts.

#### Installing the C-brake

1. Clean and blow-dry the housing.
2. Apply a film of oil to the sealing face of the C-brake housing.
3. Fit a new gasket.
4. Fit the C-brake (using two studs as guide pins).
5. Fit the attachment bolts and tighten them, in the order shown in the diagram, to the specified torque, see "Technical data".
6. Fit the C-brake connectors.
7. Adjust the C-brake play, see "Inspection and adjustment".

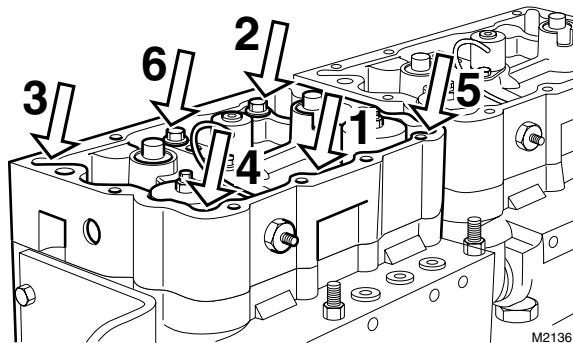
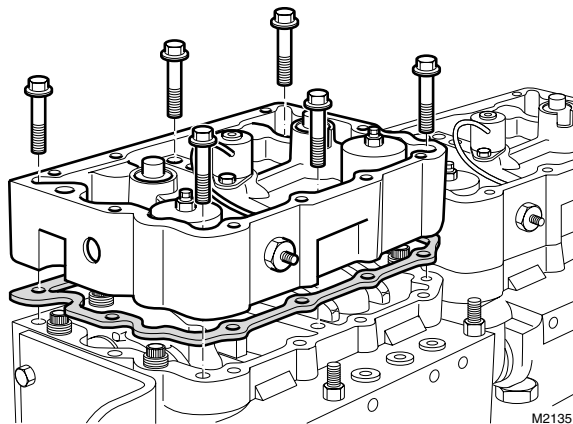



## EXPLANATORY NOTES ON THE MAINTENANCE ACTIVITIES

95XF series

Removal and installation

### 4.11 REMOVAL AND INSTALLATION, VALVE COVER

XF/XE engine



**When the engine or parts thereof are opened, it is possible for dirt to penetrate which can result in serious damage to the engine. So clean the engine thoroughly before opening any parts of it.**

#### Removing the valve cover

1. Clean the area around the valve cover.
2. Remove the attachment bolts from the valve cover.
3. Remove the valve cover and the valve cover gasket.

#### Installing the valve cover

1. Clean the sealing surface of the valve sleeve and the valve cover.
2. Fit the valve cover using a new valve cover gasket.
3. Fit the attachment bolts of the valve cover and tighten them to the specified torque. See "Technical data".

## EXPLANATORY NOTES ON THE MAINTENANCE ACTIVITIES

Removal and installation

95XF series

### VF engine

#### Removing the valve cover

1. Clean the area around the valve cover.
2. Remove the attachment bolts from the valve cover.
3. Remove the valve cover and the gasket.

#### Installing the valve cover

1. Clean the sealing face of the valve cover.
2. Fit the valve cover using the valve cover gasket.  
The valve cover gasket, if not damaged, may be reused (do not use solvents for cleaning the gasket).  
The marking "TOP" on the gasket should point in the direction of the valve cover.
3. Fit the attachment bolts of the valve cover and tighten them to the specified torque.  
See "Technical data".

5

## EXPLANATORY NOTES ON THE MAINTENANCE ACTIVITIES

95XF series

Removal and installation

### 4.12 REMOVAL AND INSTALLATION, DEB



Make sure that the spring plate (5) under the main piston (4) is not damaged or deformed.

If this spring plate is damaged or deformed it could break off while the DEB is engaged, resulting in serious engine damage.

When the engine or parts thereof are opened, it is possible for dirt to penetrate which can result in serious damage to the engine. So clean the engine thoroughly before opening any parts of it.

#### Removing the DEB

1. Remove the valve covers.
2. Disconnect the electrical connection and remove the cable harness from its housing.
3. Remove the DEB attachment bolts and the DEB assembly.

#### Installing the DEB

1. Tighten the rocker seat attachment bolts to the specified torque. See "Technical data".

#### Note:

There are two different DEB housings for cylinders 1 to 3, and cylinders 4 to 6. This is indicated on the DEB housing.

2. Place the DEB on the rocker seats.
3. Insert the DEB attachment bolts and tighten them to the specified torque. See "Technical data".
4. Connect the electrical connections.
5. Adjust the valve clearance.
6. Adjust the DEB clearance. See "Inspection and adjustment".
7. Fit the valve covers.

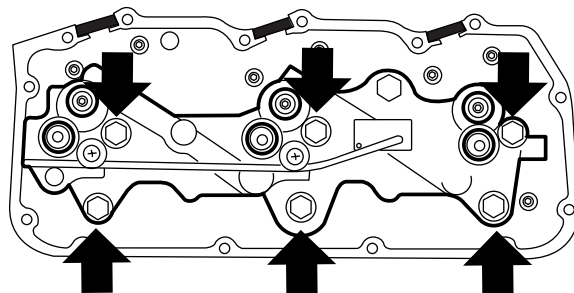
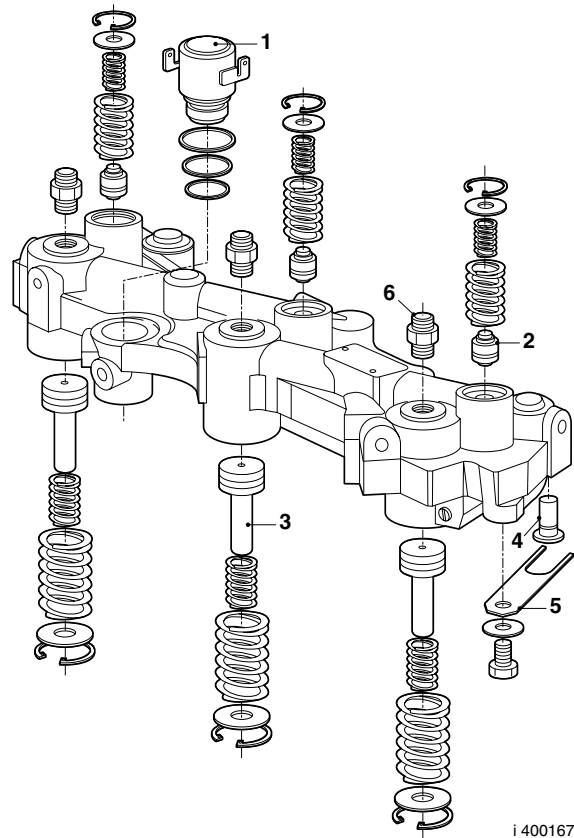

5

## EXPLANATORY NOTES ON THE MAINTENANCE ACTIVITIES

Removal and installation

95XF series

### 4.13 REMOVAL AND INSTALLATION, STEERING GEAR FILTER ELEMENT

1. Clean the reservoir cover, so that absolutely no dirt can get into the reservoir.
2. Remove the cover (3), turn filter holder (5) a quarter turn and remove the filter holder containing the filter element (6) carefully from the reservoir, so that no dirt from the filter element can get into the reservoir.
3. Remove the filter element from the filter holder.
4. Fit a new filter element on the holder and install the filter holder containing the filter in the reservoir. Make sure that the filter holder engages in its locking element.
5. Check the seal (4) on the cover (3) and fit the cover.
6. Check the fluid level using the dipstick (2), see chapter "Inspection and adjustment".

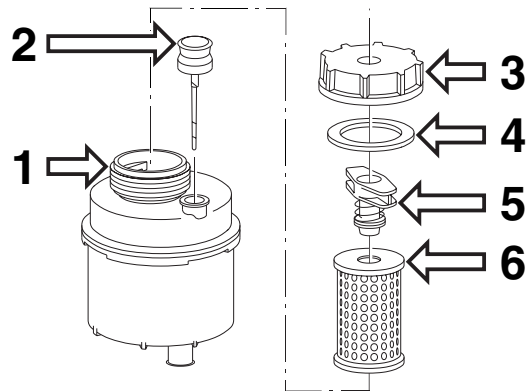

M7002

## EXPLANATORY NOTES ON THE MAINTENANCE ACTIVITIES

95XF series

Removal and installation

### 4.14 REMOVAL AND INSTALLATION, AIR DRYER FILTER ELEMENT

#### Removing the air dryer filter element

1. Remove the compressor line (1); as a result, the inside of the air dryer will become pressureless.
2. Remove the filter element by turning it counter-clockwise using a strap wrench.
3. Clean the air dryer internally.
4. Check the air dryer threaded connection (2) for damage and then lubricate it sparingly with grease.

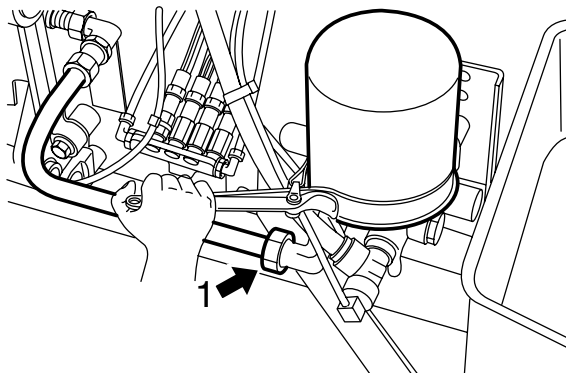

R600251

#### Installing the air dryer filter element

1. Lubricate the sealing ring of the new filter element sparingly with grease.
2. Install the filter element by manually tightening it until the sealing ring abuts. Subsequently turn the air dryer filter element one full turn by hand.
3. Fit the compressor line (1).
4. Pressurise the system and subsequently check the air dryer for possible air leakage.

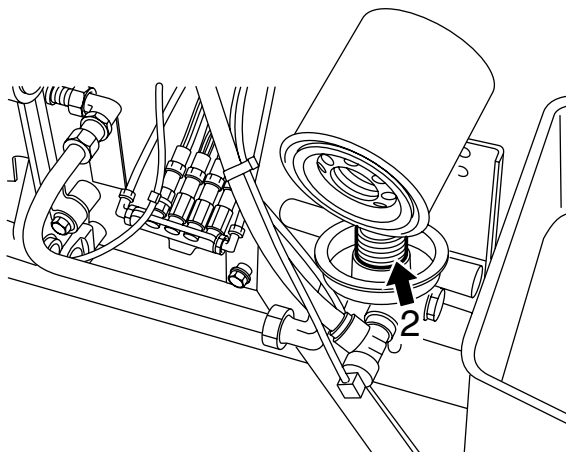

R600252

5

## EXPLANATORY NOTES ON THE MAINTENANCE ACTIVITIES

Removal and installation

95XF series

### 4.15 REMOVAL AND INSTALLATION, GEARBOX OIL FILTER



To prevent skin injury, avoid unnecessary contact with the drained oil.

Gearbox 16S-181/221 with integrated retarder

#### Removing the gearbox oil filter

1. Remove the attachment bolt (1) of the oil filter.

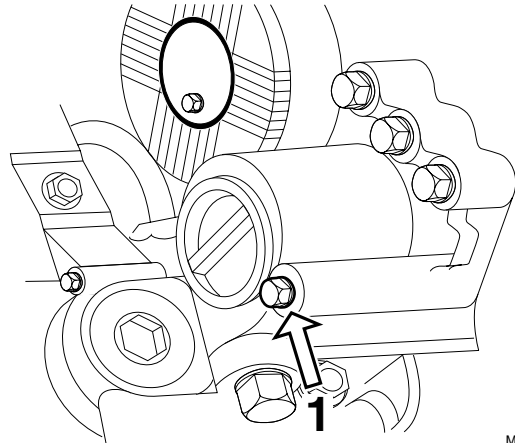

M3052

2. Pull the filter cover with the filter from the filter housing.

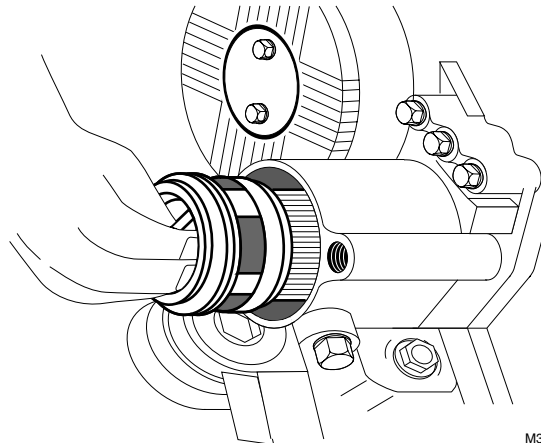

M3053

3. Remove the filter (3) from the filter cover (2). Do not clean the filter. The filter must always be replaced.

**Note:**

If the magnetic disc is still attached to the back of the filter, separate it from the filter element and fit it to the new filter element.

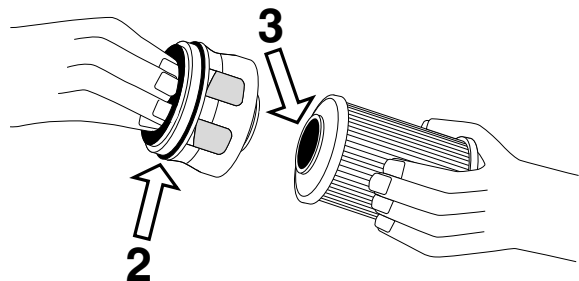

M3054

## EXPLANATORY NOTES ON THE MAINTENANCE ACTIVITIES

95XF series

Removal and installation

### Installing the gearbox oil filter

1. Check the O-ring of the filter cover (2) for any damage. Replace the O-ring if necessary. Grease the O-ring.
2. Grease the O-ring of the new filter (3) and place the filter on the filter cover. Then insert the filter and the filter cover into the filter housing.
3. Use a plastic mallet to tap the filter cover into the filter housing.
4. Tighten the attachment bolt (1) to the specified tightening torque, see "Technical data".

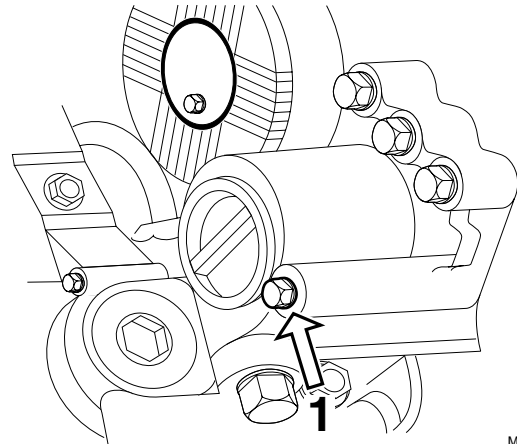

M3052

## EXPLANATORY NOTES ON THE MAINTENANCE ACTIVITIES

Removal and installation

95XF series

### 4.16 REMOVAL AND INSTALLATION, WHEEL HUB

FRONT AXLE/LEADING REAR AXLE/TRAILING AXLE 09N075

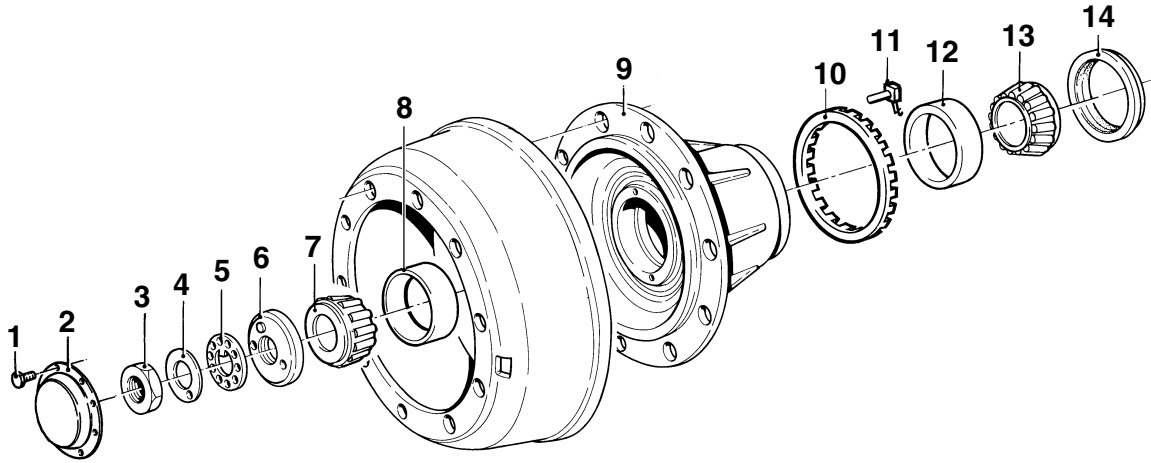

S7 00 401

5

#### Removing the wheel hub

1. Jack up the axle until the wheels are clear from the floor and position suitable stands under the axle.
2. Release the brake shoes.
3. Remove the hub cap (2).
4. Tap back the locking washer (4) and remove the lock nut (3) from the axle journal using the socket spanner (A), special tool (DAF no. 0535832).
5. Remove the locking washer (4) and the circlip (5) from the axle journal.
6. Position a tyre lift under the wheel.

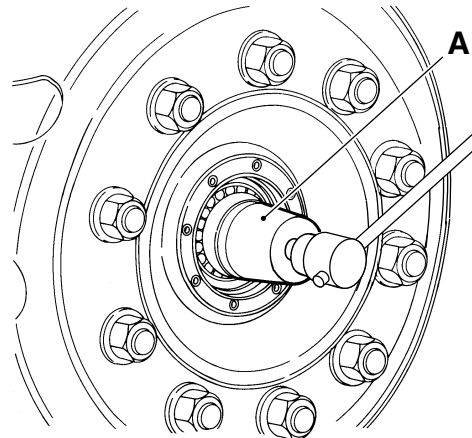

S7 00 084



## EXPLANATORY NOTES ON THE MAINTENANCE ACTIVITIES

95XF series

Removal and installation

7. Remove the adjusting nut (6) from the axle journal using adjusting spanner (A), special tool (DAF no. 0694783).
8. Remove the outer wheel bearing (7) from the hub (8).

**Note:**

If the bearings are removed from both wheels, the bearings should be marked. Each bearing should be reinstalled in its original hub.

9. Remove the hub with the wheel from the axle journal.  
Avoid damaging the wheel speed sensor ring (10).
10. Remove the hub seal (14).
11. Remove the inner wheel bearing (13) from the hub.
12. Remove the grease from the hub (9) and clean the hub.
13. Thoroughly clean the bearing cages using a cleaning liquid.
14. Remove the outer races (8) and (12) of the wheel bearings, if necessary.

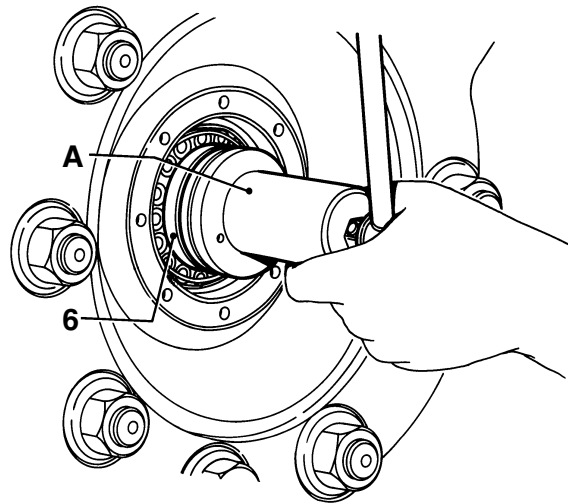

S7 00 404

5

## EXPLANATORY NOTES ON THE MAINTENANCE ACTIVITIES

Removal and installation

95XF series

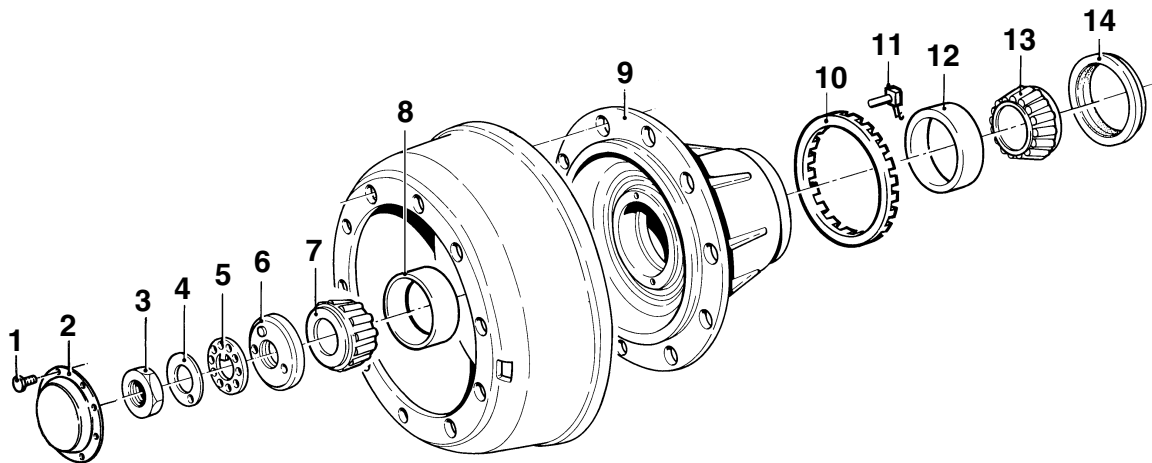

S7 00 401

5

### Installing the wheel hub

1. Check the wheel hub and the wheel bearings for wear and damage, see "Inspection and adjustment".
2. Fit a new wheel speed sensor ring (10) to the hub, if necessary.
3. Fit new wheel bearings into the hub, if necessary.
4. Blow-dry the wheel bearings (7) and (13) using compressed air.
5. Fill the wheel bearings with the specified wheel bearing grease. Also apply a layer of grease to the wheel bearing circumference.
6. Fit the wheel bearing (13) into the hub (9).
7. Fill the inside circumference of the hub with wheel bearing grease.
8. Fit a new hub seal (14) in the hub (9).
9. Apply a little grease to the sealing lips of the seal (14).
10. Check that the wheel speed sensor (11) is correctly clamped in the stub axle. Replace the clamping sleeve of the sensor, if necessary.
11. Position the wheel in front of the axle journal using the tyre lift. Fit the outer wheel bearing (7) into the hub so that the outer wheel bearing can also serve as a guide when installing the hub.

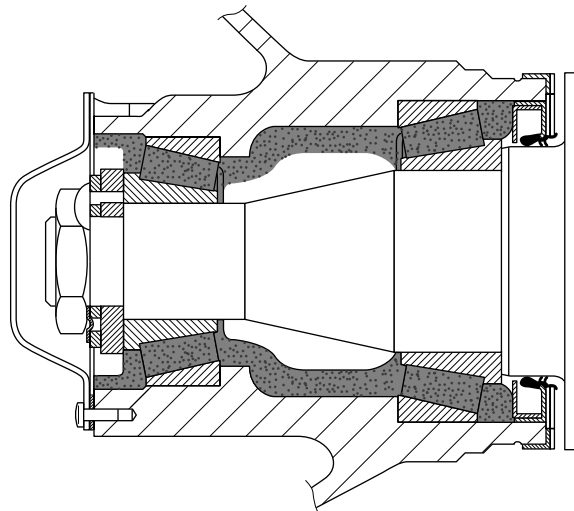

S7 00 140

## EXPLANATORY NOTES ON THE MAINTENANCE ACTIVITIES

95XF series

Removal and installation

12. Slide the hub over the axle journal. Do not pry, as the oil seal (14) might be damaged in the process.
13. Fit the adjusting nut (6) to the axle journal.
14. Adjust the specified wheel bearing play (see chapter "Inspection and adjustment") and fit the circlip (5) to the axle journal.
15. Fit a new locking washer (4) to the axle journal. The washer cam (see the arrow) should catch in one of the holes of the circlip (5).

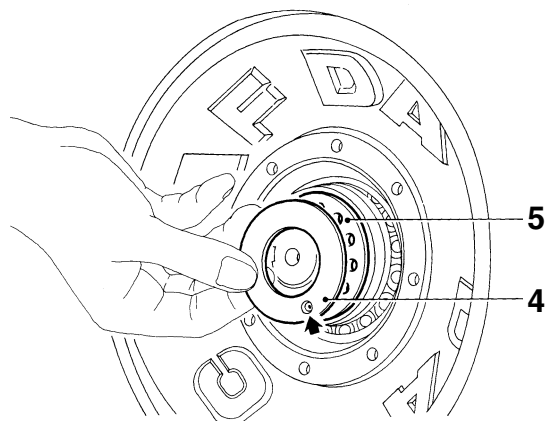

S7 00 402

16. Fit the lock nut (3) to the axle journal. Tighten the lock nut (3) to the specified tightening torque. See "Technical data". Use a socket spanner (A) for this, special tool (DAF no. 0535832).

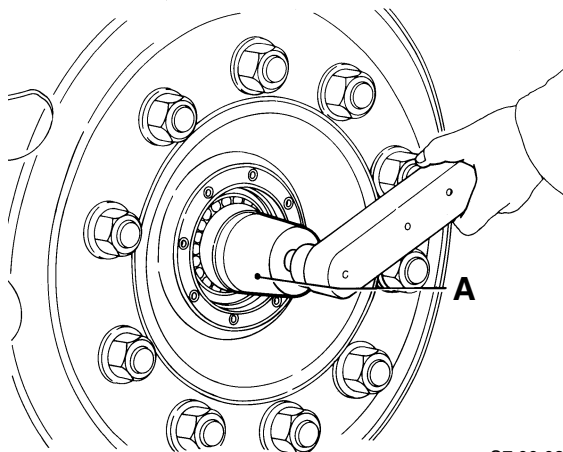

S7 00 087

17. Secure lock nut (3) by tapping back the locking washer (4) against the side of the lock nut.
18. Apply the specified grease to the front of the outer wheel bearing.
19. Clean the hub (9) sealing surfaces and the hub cap (2), and make sure they are dry and free of grease.
20. Apply a locking compound to the hub (9) sealing face.
21. Fit the hub cap (2). Tighten the bolts (1) to the specified torque. See "Technical data".
22. Press the wheel speed sensor (11) up against the sensor ring (10). While the vehicle is being driven, the air gap between the wheel speed sensor (11) and the sensor ring (10) is adjusted automatically.
23. Adjust the brakes.

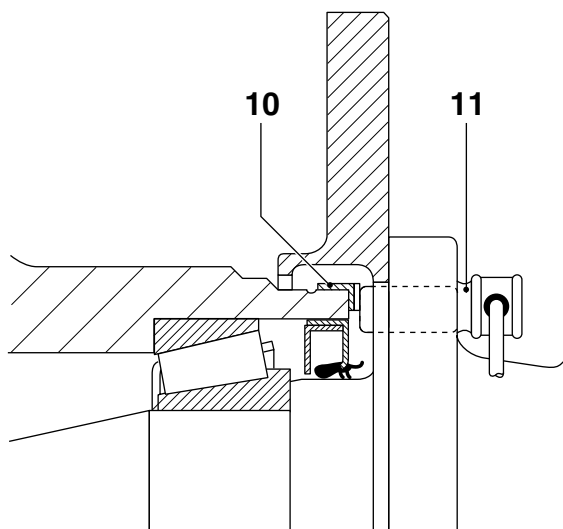

S7 00 403

5

## EXPLANATORY NOTES ON THE MAINTENANCE ACTIVITIES

Removal and installation

95XF series

### LEADING REAR AXLE 09N044 (FTP-TYPE VEHICLES)

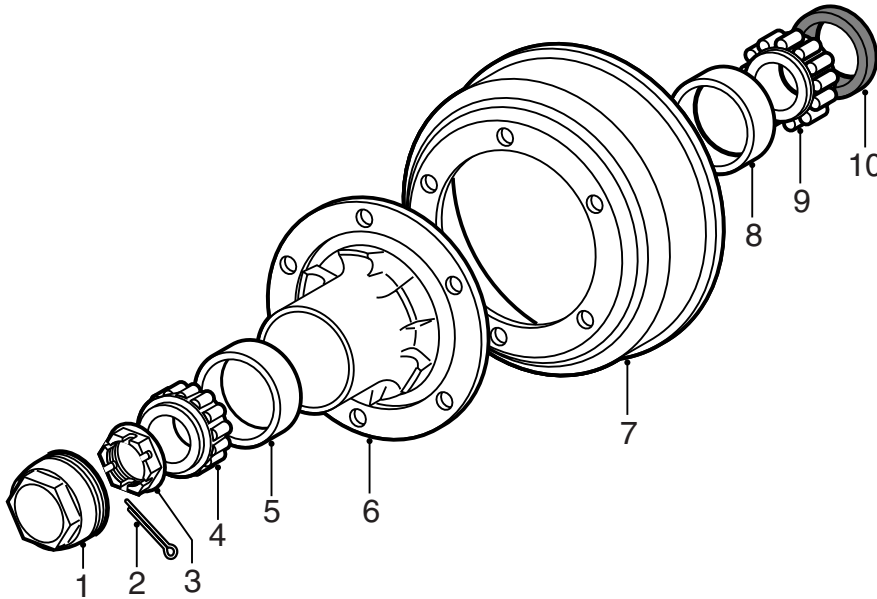

S7 00 640

5

#### Removing the wheel hub

1. Remove the hub cap (1) using special tool (DAF no. 1329498).
2. Lift the leading rear axle and support it properly.
3. Remove the split pin (2) and the hub nut (3).
4. Remove the outer wheel bearing (4).
5. Remove the hub (6) with the wheel.

#### Installing the wheel hub

1. Apply new grease to the hub (6).
2. Install the hub with the wheel.
3. Install the outer wheel bearing (4).
4. Fit the hub nut (3).
5. Adjust the wheel bearing play, see chapter "Inspection and adjustment".
6. Fit the split pin (2).
7. Lower the leading rear axle.
8. Fit the hub cap using special tool (DAF no. 1329894). Tighten the hub cap to the specified torque, see "Technical data".
9. Adjust the brakes.

## EXPLANATORY NOTES ON THE MAINTENANCE ACTIVITIES

95XF series

Removal and installation

### TRAILING AXLE 09N220

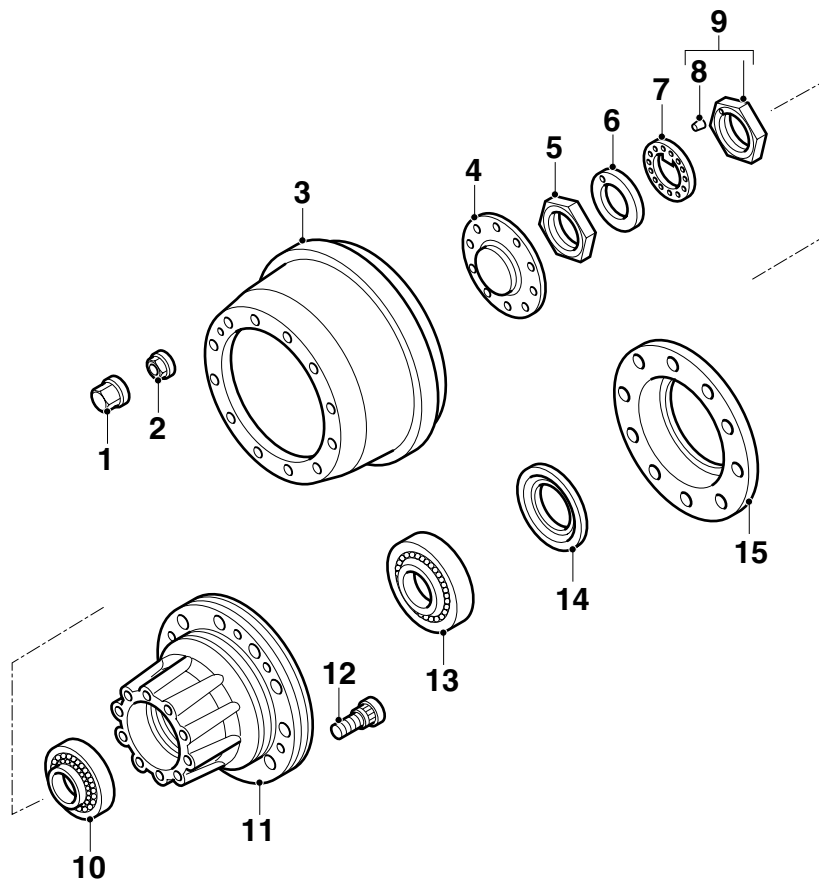

A800267

#### Removing the wheel hub

1. Remove the attachment bolts from the hub cap and remove the hub cap (4).
2. Lift the trailing axle using the trailing axle load transfer device.
3. Release the brakes.
4. Tap back the locking washer (6) and remove the lock nut (5) using special tool (DAF no. 0535648).
5. Remove the locking washer (6) and the circlip (7) from the axle journal.
6. Position a tyre lift under the wheel.
7. Remove the hub nut (9) using special tool (DAF no. 0535648).
8. Remove the outer wheel bearing (10) from the hub.

5

## EXPLANATORY NOTES ON THE MAINTENANCE ACTIVITIES

---

Removal and installation

**95XF** series

**Note:**

If the bearings are removed from both wheels, the bearings should be marked. Each bearing should be re-installed in its original hub.

9. Remove the hub with the wheel from the axle journal.
10. Remove the hub seal (14).
11. Remove the inner wheel bearing (13) from the hub.
12. Remove the grease from the hub and clean it.
13. Clean the bearings.
14. Remove the outer races of the wheel bearings, if necessary.

## EXPLANATORY NOTES ON THE MAINTENANCE ACTIVITIES

95XF series

Removal and installation

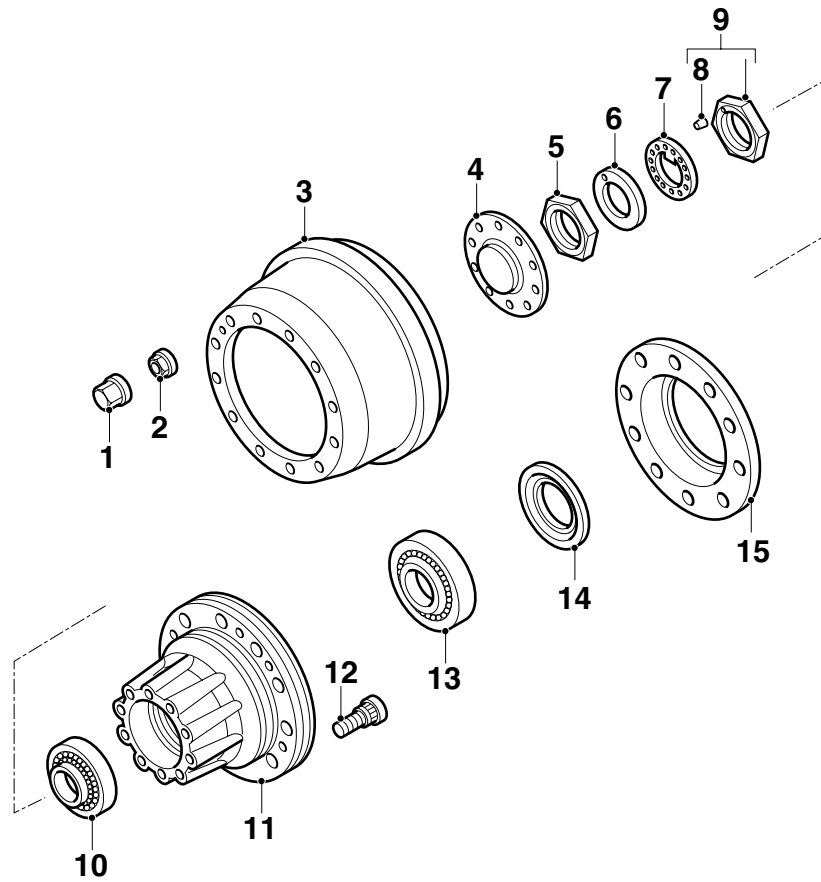

5

### Installing the wheel hub

1. Check the hub and the wheel bearings for wear and damage. See chapter "Inspection and adjustment".
2. Fit new wheel bearings into the hub, if necessary.
3. Blow-dry the wheel bearings (10) and (13) using compressed air.
4. Fill the wheel bearings with the specified wheel bearing grease. Also apply a layer of grease to the wheel bearing circumference.

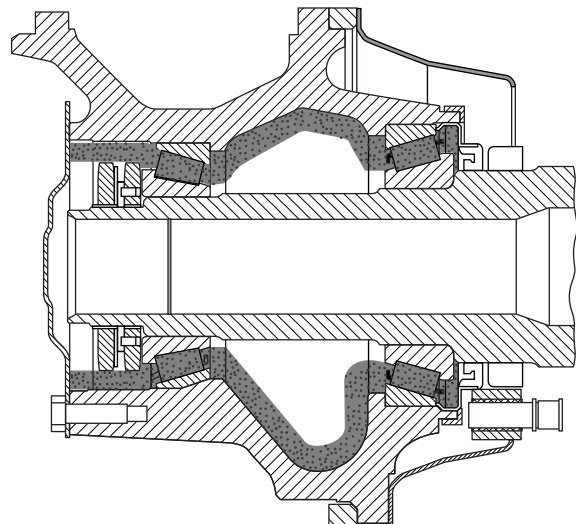

A8 00 401

## EXPLANATORY NOTES ON THE MAINTENANCE ACTIVITIES

### Removal and installation

95XF series

5. Fit the wheel bearing (13) into the hub.
6. Fill the inside circumference of the hub with wheel bearing grease.
7. Fit a new hub oil seal (14) in the hub.
8. Apply a little grease to the sealing lips of the seal.
9. Position the wheel in front of the axle journal using the tyre lift.  
Fit the outer wheel bearing (10) into the hub so that the outer wheel bearing can also serve as a guide when installing the hub.
10. Slide the hub over the axle journal. Do not pry, as the oil seal (14) might be damaged in the process.
11. Fit the hub nut (9) to the axle journal.
12. Adjust the specified wheel bearing play (see chapter "Inspection and adjustment") and fit the circlip (7) to the axle journal.
13. Fit a new locking washer (6) to the axle journal. The cam of the locking washer should fall into one of the holes of the circlip (7).
14. Fit the lock nut (5) to the axle journal. Tighten the lock nut (5) to the specified tightening torque. See "Technical data". Use special tool (DAF no. 0535648).
15. Secure lock nut (5) by tapping back the locking washer (6) against the side of the lock nut.
16. Apply the specified grease to the front of the outer wheel bearing.
17. Fit the hub cap (4) applying a sealant.
18. Adjust the brakes.



## **EXPLANATORY NOTES ON THE MAINTENANCE ACTIVITIES**

**95XF** series

Removal and installation

### **4.17 REMOVAL AND INSTALLATION, HUB OIL SEAL**

#### **FRONT AXLE/LEADING REAR AXLE AND TRAILING AXLES 9N075/09N220**

##### **Removing the hub oil seal**

1. Remove the hub from the axle journal.
2. Drill two holes into the oil seal and screw the special tool (DAF no. 0484899) into the oil seal. Pull the oil seal from the wheel hub using the special tool (DAF no. 0694928).

## EXPLANATORY NOTES ON THE MAINTENANCE ACTIVITIES

Removal and installation

95XF series

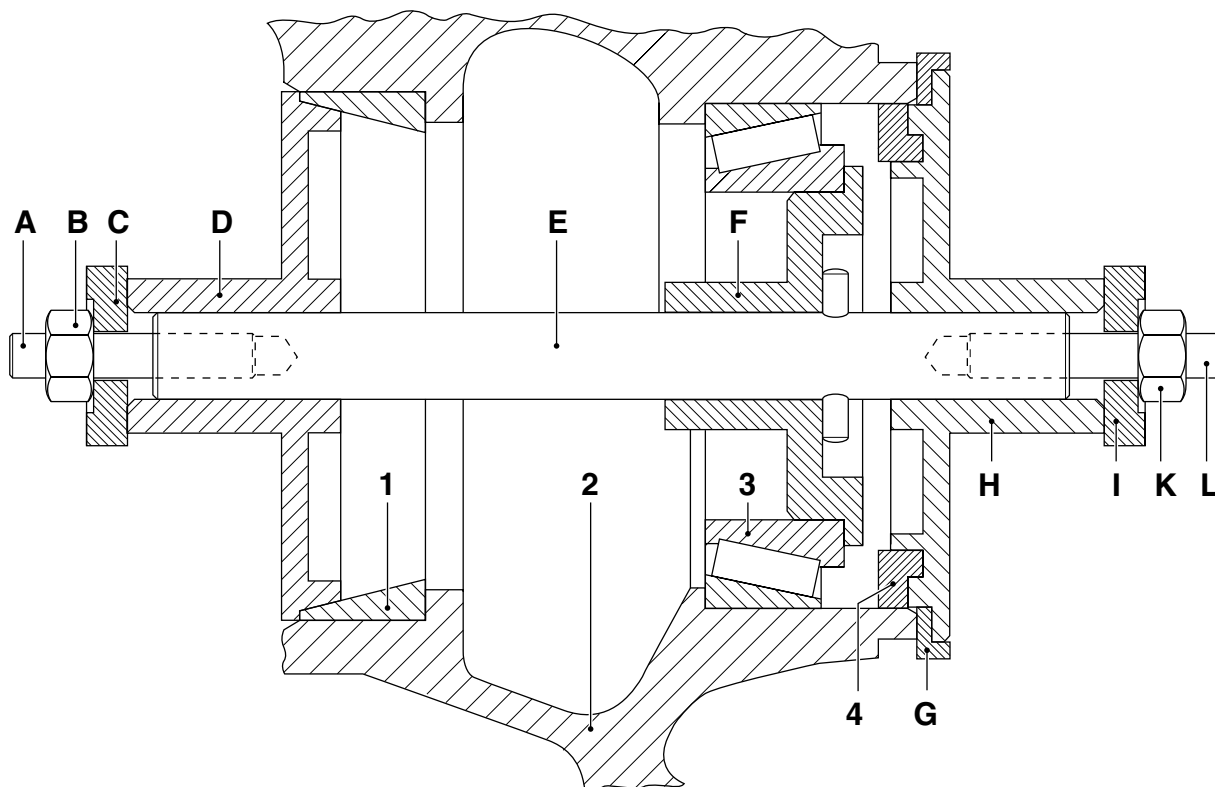

5

S7 00 180

### Installing the hub oil seal

1. Check the seal chamber (4) in the hub (2) for damage.
2. For the installation of the hub oil seal (4) use special tool (DAF no. 1240036).
3. Assemble the special tool: turn the threaded ends (A) and (L) into the centring spindle (E). Assemble the short stud (L) on the side where the pin is located in the centring spindle (E).
4. Slide the appropriate centring flange (F) over the centring spindle (E).
5. Install the inner wheel bearing (3). Slide the centring spindle (E) with the centring flange (F) into the hub (2).
6. Press the centring flange (F) into the inner wheel bearing (3).

## EXPLANATORY NOTES ON THE MAINTENANCE ACTIVITIES

95XF series

Removal and installation

7. Slide the appropriate centring flange (D) on the centring spindle (E).
8. Fit the locking plate (C) and the nut (B) on the centring spindle (E).
9. Align the centring flange (D) on the outer race of the outer wheel bearing and hand-tighten nut (B) (max. 20 Nm). The centring spindle (E) must be installed in the hub (2) free of play.

**Note:**

Fit the dummy sensor ring (G) to the draw-in flange (H) if the wheel hub (2) is **note**quipped with a sensor ring (5). Fit the draw-in flange (H) without the dummy sensor ring if the hub (2) **does** have a sensor ring (5).

10. Position the seal (4) in front of the hub with the seal lip pointing to the outside of the hub. Slide the draw-in flange (H) over the centring spindle (E) against the seal (4).
11. Fit the locking plate (I) and the nut (K).
12. Push the seal (4) evenly into the hub (2) using the nut (K). In the case of a hub **with** sensor ring (5) the oil seal should be pressed in until draw-in flange (H) abuts the sensor ring (5). In the case of a wheel hub **without** sensor ring (5) the oil seal should be pressed in until the dummy sensor ring (G) abuts the hub rim.
13. Remove the special tool.
14. Apply grease to the sealing lips of the oil seal (4).
15. Install the hub on the axle journal.

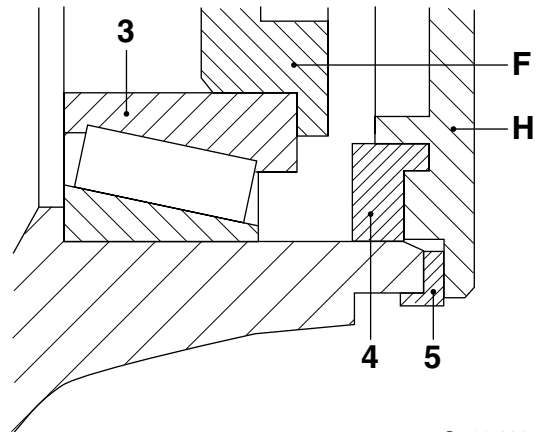

S7 00 182

5

## **EXPLANATORY NOTES ON THE MAINTENANCE ACTIVITIES**

---

Removal and installation

**95XF** series

### **LEADING REAR AXLE 09N044 (FTP-TYPE VEHICLES)**

#### **Removing the hub oil seal**

1. Remove the hub from the axle journal.
2. Drill two holes into the oil seal and screw the special tool (DAF no. 0484899) into the oil seal. Pull the oil seal from the wheel hub using the special tool (DAF no. 0694928).

#### **Installing the hub oil seal**

1. Check the seal chamber for damage.
2. For installation of the hub oil seal (4) use special tool (DAF no. 1329497).
3. Apply a little grease to the sealing lips of the oil seal.
4. Install the hub on the axle journal.

## EXPLANATORY NOTES ON THE MAINTENANCE ACTIVITIES

95XF series

Removal and installation

### 4.18 REMOVAL AND INSTALLATION, HUB OIL SEAL/WHEEL SPEED SENSOR RING UNIT

#### Removing the hub seal/wheel speed sensor ring

1. Remove the hub from the axle journal.
2. Fit the special tool (3) (DAF no. 1329411) to the impact puller (2), special tool (DAF no. 0694928). Hook special tool (3) (DAF no. 1329411) behind the oil seal (1). Pull the seal (1) from the hub using impact puller (2). The removed seal (1) cannot be used again.

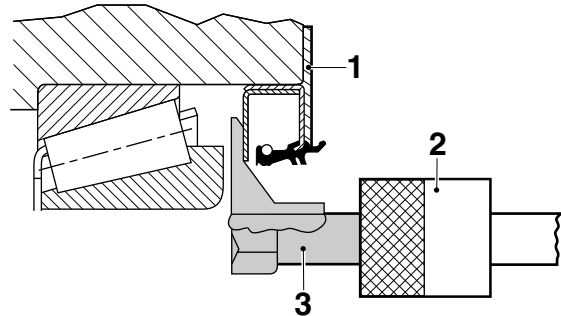

S7 00 424

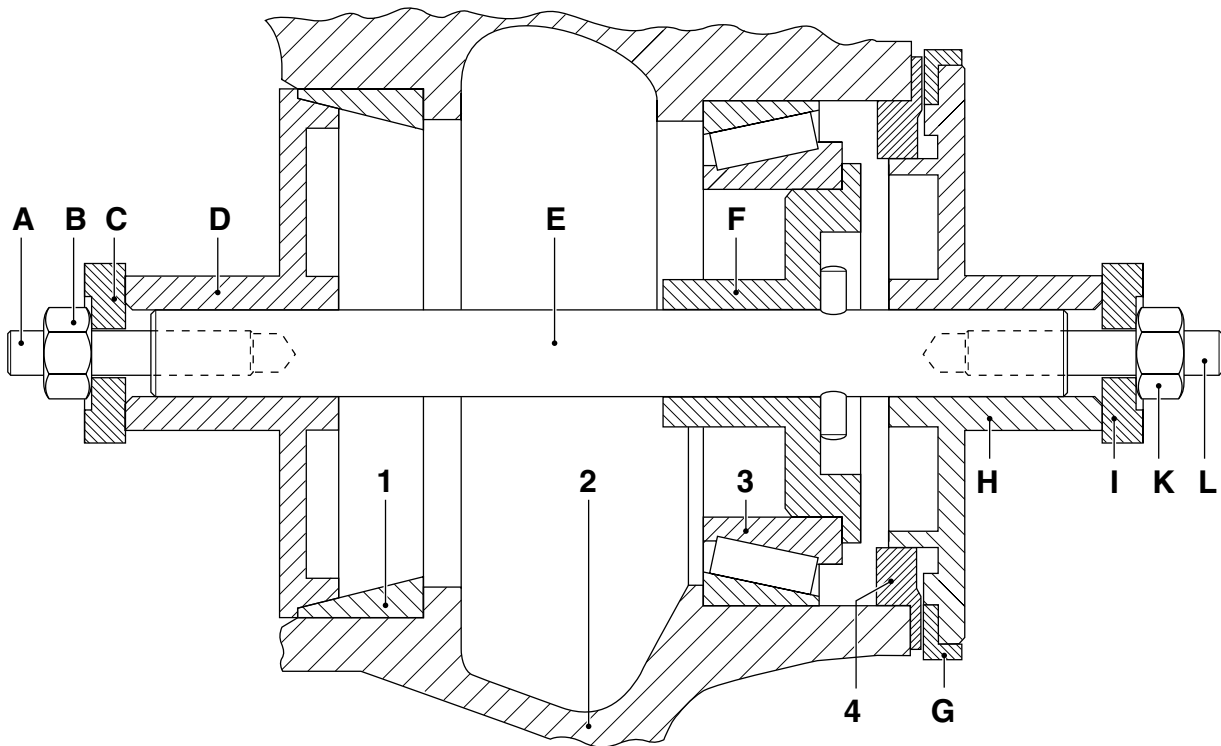

S7 00 405

#### Installing the hub seal/wheel speed sensor ring

1. Check the seal chamber (4) in the hub (2) for damage.
2. For the installation of the hub oil seal (4) use special tool (DAF no. 1240036).

5

## EXPLANATORY NOTES ON THE MAINTENANCE ACTIVITIES

### Removal and installation

95XF series

5

3. Assemble the special tool: turn the threaded ends (A) and (L) into the centring spindle (E).  
Assemble the short stud (L) on the side where the pin is located in the centring spindle (E).
4. Slide the appropriate centring flange (F) over the centring spindle (E).
5. Install the inner wheel bearing (3).
6. Slide the centring spindle (E) with the centring flange (F) into the hub (2).
7. Press the centring flange (F) into the inner wheel bearing (3).
8. Slide the appropriate centring flange (D) on the centring spindle (E).
9. Fit the locking plate (C) and the nut (B) on the centring spindle (E).
10. Align the centring flange (D) on the outer race of the outer wheel bearing and hand-tighten nut (B) (max. 20 Nm). The centring spindle (E) must be installed in the hub (2) free of play.
11. Fit the ring (G) on the draw-in flange (H).
12. Position the seal (4) in front of the hub (2). Slide the draw-in flange (H) with the washer (G) over the centring spindle (E) against the seal (4).
13. Fit the locking plate (I) and the nut (K).
14. Press the oil seal (4) evenly into the wheel hub (2) using nut (K), until the sensor ring abuts the wheel hub (2).
15. Remove the special tool.
16. Apply grease to the sealing lips of the oil seal (4).
17. Install the hub on the axle journal.

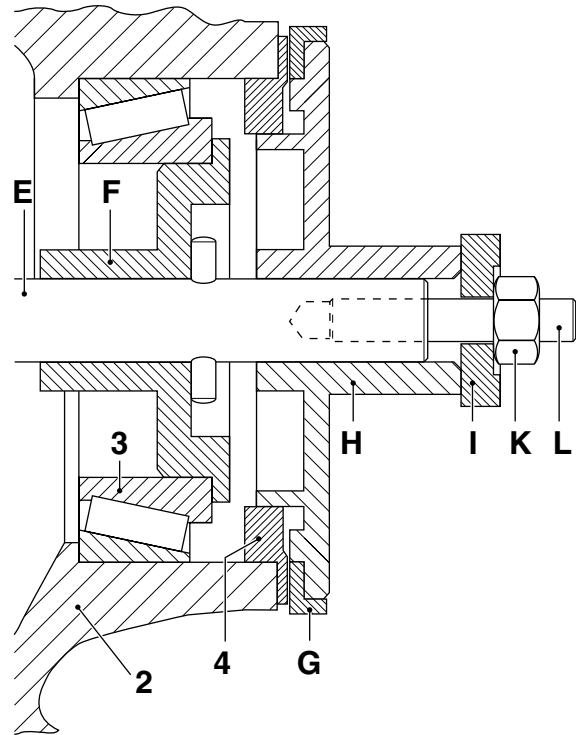

S7 00 411

## EXPLANATORY NOTES ON THE MAINTENANCE ACTIVITIES

95XF series

Draining and filling

### 5. DRAINING AND FILLING

#### 5.1 TOPPING UP BATTERY FLUID



**Avoid sparks and open flames in the vicinity of batteries. Battery acid is an aggressive fluid.**

**In the event of contact with the skin: rinse the skin with plenty of water for a sustained period. If redness or pain persists, consult a doctor. Remove any clothing affected and rinse with water.**

**In the event of contact with the eyes: rinse with plenty of water for at least 15 minutes and see a doctor.**

**If swallowed: do NOT induce vomiting. Rinse the mouth, drink two glasses of water and see a doctor.**

**In the event of inhalation: get some fresh air, rest and consult a doctor.**

#### **Topping up battery fluid**

1. Clean the top of the battery. If the top side of the battery is contaminated with acid, it should be rinsed with water.
2. Remove the plugs and top up the batteries with distilled water to approximately 10 mm above the plates or up to the "max" indicator level.

## EXPLANATORY NOTES ON THE MAINTENANCE ACTIVITIES

Draining and filling

95XF series

### 5.2 DRAINING AND FILLING, ENGINE OIL



To prevent skin injury, avoid unnecessary contact with the drained oil.

#### XF/XE ENGINE

##### Draining engine oil

1. Position the vehicle on a level surface.
2. Drain the oil using the drain plug in the oil sump.
3. Replace the drain plug oil seal and tighten the drain plug to the specified torque. See "Technical data".

##### Refilling engine oil

1. Fill the engine through oil-filler pipe (D) with the specified engine-oil quantity. See "Technical data".

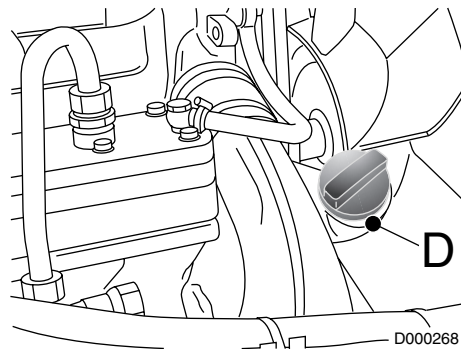

5

#### VF ENGINE

##### Draining engine oil

1. Position the vehicle on a level surface.
2. Drain the oil using the drain plug in the oil sump.
3. Replace the drain plug oil seal and tighten the drain plug to the specified torque. See "Technical data".

##### Refilling engine oil

1. Fill the engine through the filler opening in the valve cover with the specified engine oil quantity. See "Technical data".



## EXPLANATORY NOTES ON THE MAINTENANCE ACTIVITIES

95XF series

Draining and filling

### 5.3 DRAINING AND FILLING/BLEEDING, COOLING SYSTEM



In order to avoid damaging the cylinder block, do not top up a warm engine with cold coolant.

Coolant is a toxic fluid and must be handled with care. Protect skin and eyes.

Coolant is harmful to the environment; after use, it should be processed as industrial chemical waste.

When the coolant is hot, there is overpressure in the cooling system. When removing the filler cap, allow the overpressure to escape by first loosening the filler cap one turn.

#### XF/XE ENGINE

##### Draining the cooling system

1. Turn the heater control knob to the "warmest" temperature setting. As a result, the heater valve will be fully opened.
2. Remove the cooling system filler cap.
3. Collect the coolant. Position suitable containers under the drain points.
4. Drain the cooling system at the cylinder block via the drain tap (A) and the radiator via the drain plug (B). If an integrated retarder is used, remove the coolant drain plug of the heat exchanger.
5. Flush the cooling system.
6. Close the drain tap (A) and fit the drain plug (B).

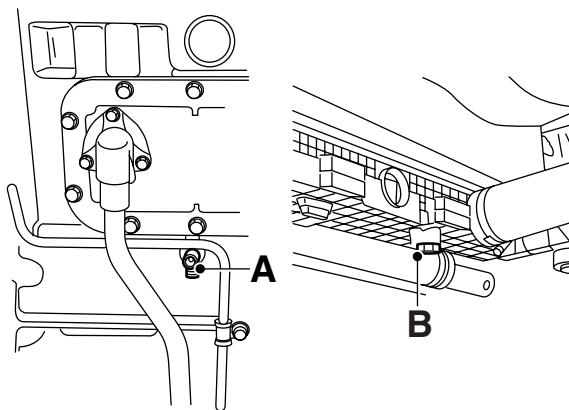

M200556

5

## EXPLANATORY NOTES ON THE MAINTENANCE ACTIVITIES

### Draining and filling

95XF series

#### Filling/bleeding the cooling system

1. Turn the heater temperature control knob in the cab to the "warmest" setting.
2. Fill the cooling system with the specified coolant.
3. Run the engine for several minutes.
4. The cooling system is auto-bleeding. Ensure that the vent line from the thermostat housing to the expansion tank is not kinked or pinched off.
5. Check the coolant level, and top up with coolant if necessary.

#### If the vehicle is equipped with water/air cab heater

1. Run the engine at idling speed.
2. Switch on the cab heater, using the rocker switch on the dashboard.
3. Turn the heater temperature control knob in the cab to the "warmest" setting.
4. Switch on the heater fan.
5. Set the rocker switch on the thermostat in the cab to position 1.

**Note:**

Combustion will start after approximately one minute.

6. Allow the cab heater to operate for approximately 15 minutes.
7. Then check the coolant level.

## EXPLANATORY NOTES ON THE MAINTENANCE ACTIVITIES

95XF series

Draining and filling

### VF ENGINE

#### Draining the cooling system

1. Turn the heater control knob to the "warmest" temperature setting. As a result, the heater valve will be fully opened.
2. Remove the cooling system filler cap.
3. Collect the coolant. Position suitable containers under the drain points.
4. Drain the cooling system at the cylinder block via drain tap (A), at the radiator via drain plug (B) and at the heat exchanger via drain plug (C).
5. Flush the cooling system.
6. Close drain taps (A) and (C) and install drain plug (B).

#### Filling/bleeding the cooling system

1. Turn the heater temperature control knob in the cab to the "warmest" setting.
2. Fill the cooling system with the specified coolant.
3. Run the engine for several minutes.
4. The cooling system is auto-bleeding. Ensure that the vent line from the thermostat housing to the expansion tank is not kinked or pinched off.
5. Check the coolant level, and top up with coolant if necessary.

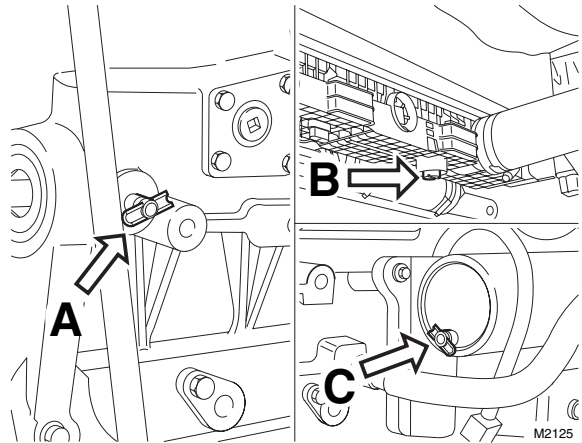

## EXPLANATORY NOTES ON THE MAINTENANCE ACTIVITIES

---

Draining and filling

95XF series

### If the vehicle is equipped with water/air cab heater

1. Run the engine at idling speed.
2. Switch on the cab heater, using the rocker switch on the dashboard.
3. Turn the heater temperature control knob in the cab to the "warmest" setting.
4. Switch on the heater fan.
5. Set the rocker switch on the thermostat in the cab to position 1.

**Note:**

Combustion will start after approximately one minute.

6. Allow the cab heater to operate for approximately 15 minutes.
7. Then check the coolant level.

## EXPLANATORY NOTES ON THE MAINTENANCE ACTIVITIES

95XF series

Draining and filling

### 5.4 DRAINING AND FILLING, DIFFERENTIAL



To prevent skin injury, avoid unnecessary contact with the drained oil.

#### 1347 axle

##### Draining the differential

1. Position the vehicle on a level surface.
2. Remove the level check/filler plug (A) and drain plug (B) and drain the oil.

##### Filling the differential

1. Position the vehicle on a level surface.
2. Fit the drain plug (B) using the special torx spanner (DAF no. 1329422) and tighten it to the specified torque. See "Technical data".
3. Fill the differential with the specified quantity of oil. See "Technical data".
4. Check the oil level after approximately 5 minutes. See "Inspection and adjustment".
5. Fit the level check/filler plug (A) using the special torx wrench (DAF no.1329422) and tighten the plug to the specified tightening torque. See "Technical data".

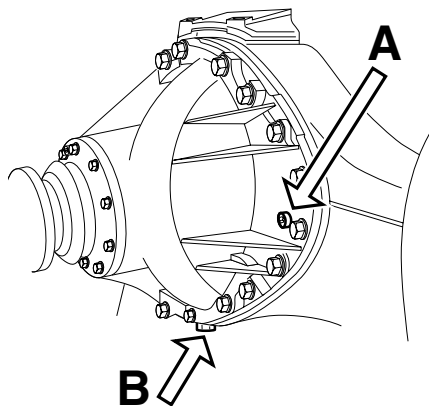

M8013

5

## EXPLANATORY NOTES ON THE MAINTENANCE ACTIVITIES

Draining and filling

95XF series

### 1354 axle

#### Draining the differential

1. Position the vehicle on a level surface.
2. Lower the trailing axle, if present, on a leaf-sprung version.
3. Remove the level check/filler plug (A) and drain plug (B) and drain the oil.

#### Filling the differential

1. Position the vehicle on a level surface.
2. Fit the drain plug (B) using the special torx spanner (DAF no. 1329422) and tighten it to the specified torque. See "Technical data".
3. Fill the differential with the specified quantity of oil. See "Technical data".
4. Check the oil level after approximately 5 minutes. See "Inspection and adjustment".
5. Fit the level check/filler plug (A) using the special torx wrench (DAF no.1329422) and tighten the plug to the specified tightening torque. See "Technical data".

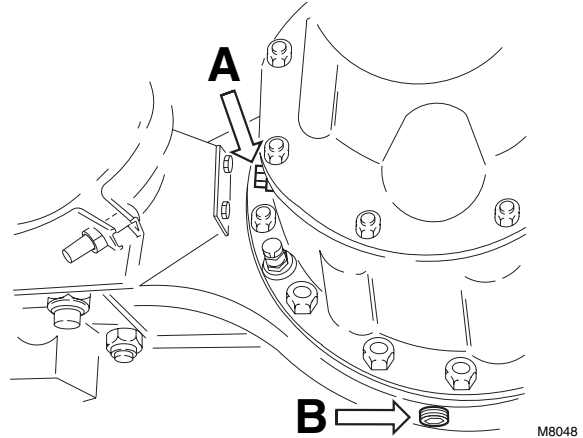

## EXPLANATORY NOTES ON THE MAINTENANCE ACTIVITIES

95XF series

Draining and filling

### 1355 (T) axle

#### Draining the differential, first axle

1. Position the vehicle on a level surface.
2. Remove the level check/filler plug (A) and drain plugs (B) and drain the oil.

#### Filling the differential, first axle

1. Position the vehicle on a level surface.
2. Fit the drain plugs (B) using the special torx spanner (DAF no. 1329422) and tighten them to the specified torque. See "Technical data".
3. Fill the differential with the specified quantity of oil. See "Technical data".
4. Check the oil level after approximately 5 minutes. See "Inspection and adjustment".
5. Fit the level check/filler plug (A) using the special torx wrench (DAF no.1329422) and tighten the plug to the specified tightening torque. See "Technical data".

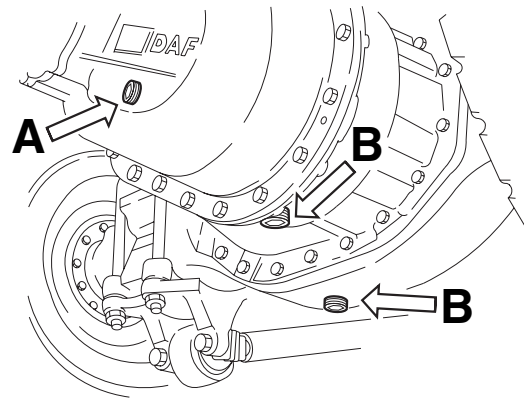

M8049

#### Draining the differential, second axle

1. Position the vehicle on a level surface.
2. Remove the level check/filler plug (A) and drain plug (B) and drain the oil.

#### Filling the differential, second axle

1. Position the vehicle on a level surface.
2. Fit the drain plug (B) using the special torx spanner (DAF no. 1329422) and tighten it to the specified torque. See "Technical data".
3. Fill the differential with the specified quantity of oil. See "Technical data".
4. Check the oil level after approximately 5 minutes. See "Inspection and adjustment".
5. Fit the level check/filler plug (A) using the special torx wrench (DAF no.1329422) and tighten the plug to the specified tightening torque. See "Technical data".

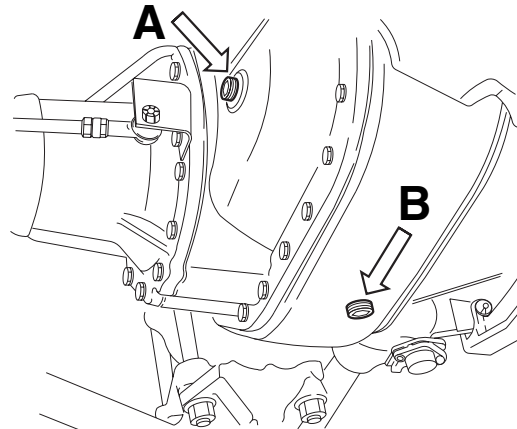

M8050

5

## EXPLANATORY NOTES ON THE MAINTENANCE ACTIVITIES

Draining and filling

95XF series

### 5.5 DRAINING AND FILLING, WHEEL HUB



To prevent skin injury, avoid unnecessary contact with the drained oil.

#### 1347 axle

##### Draining the wheel hub

1. Position the vehicle on a level surface.
2. Position the wheels so that the level check/filler plug (A) is at the underside.
3. Remove the level check/filler plug (A) and drain the oil.

##### Filling the wheel hub

1. Position the vehicle on a level surface.
2. Position the wheels so that the arrow on the hub cover is facing upwards vertically.
3. Fill the hub with the specified quantity of oil. See "Technical data".
4. Check the oil level after approximately 5 minutes. See "Inspection and adjustment".
5. Fit the level check/filler plug (A) ) using the special Torx wrench (DAF no.1329422) and tighten the plug to the specified tightening torque. See "Technical data".

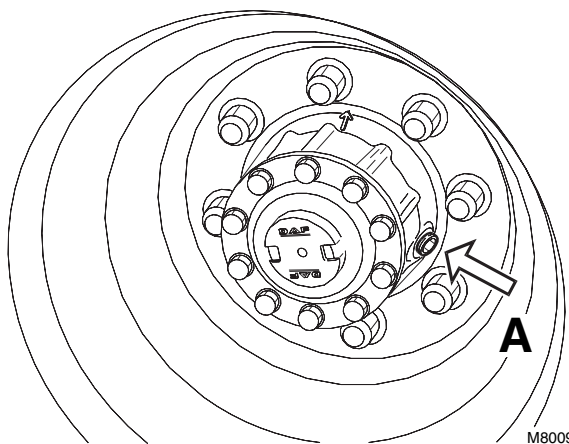
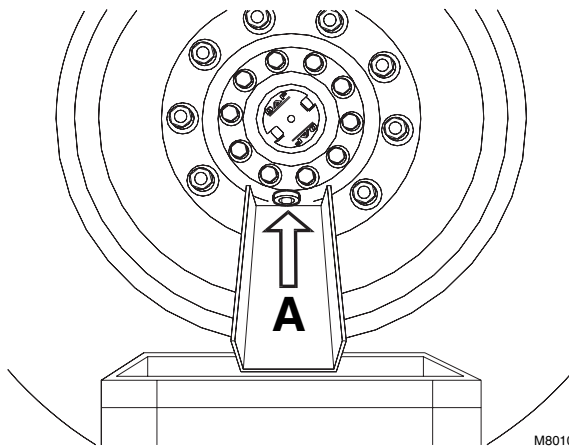



## EXPLANATORY NOTES ON THE MAINTENANCE ACTIVITIES

95XF series

Draining and filling

### 1354 and 1355 (T) axle

#### Draining the wheel hub

1. Position the vehicle on a level surface.
2. Position the wheels in such a way that the drain/filler plug (A) is on the underside.
3. Remove the drain/filler plug (A) and level check plug (B) and drain the oil.

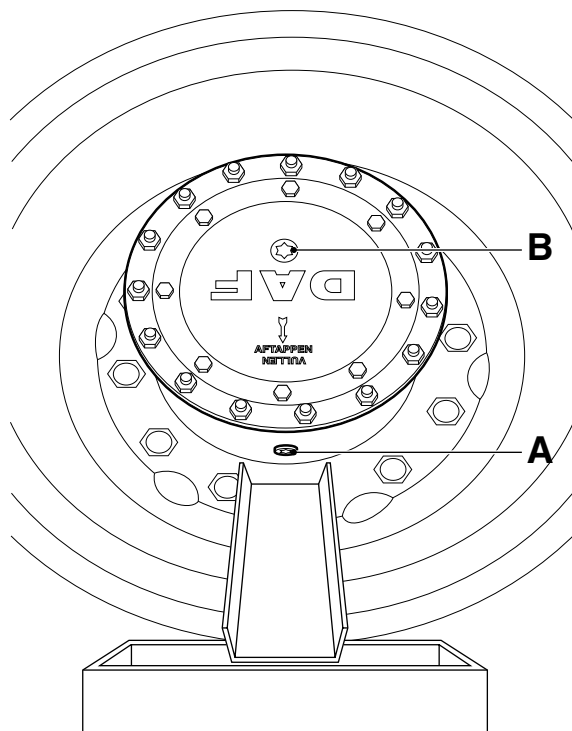

A8 00 363

#### Filling the wheel hub

1. Position the vehicle on a level surface.
2. Position the wheels in such a way that the drain/filler plug (A) is on the top side.
3. Fill the hub with the specified quantity of oil. See "Technical data".
4. Check the oil level after approximately 5 minutes. See "Inspection and adjustment".
5. Fit the level check plug (B) and the drain/filler plug (A) using the special torx wrench (DAF no. 1329422) and tighten the plug to the specified tightening torque. See "Technical data".

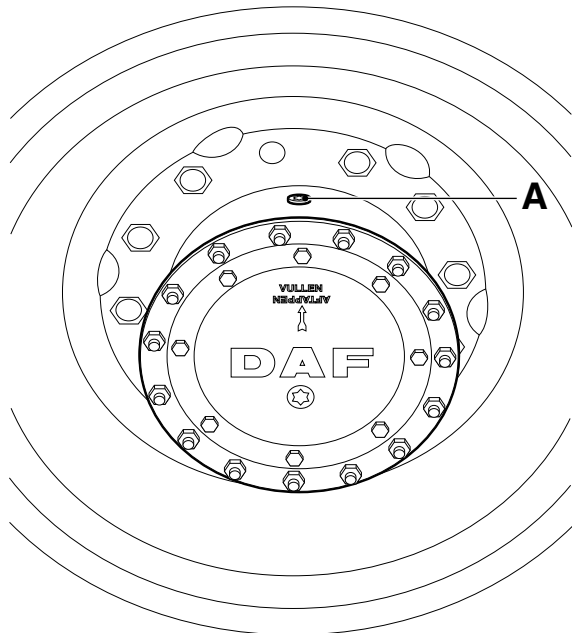

A8 00 364

5

## EXPLANATORY NOTES ON THE MAINTENANCE ACTIVITIES

Draining and filling

95XF series

### 5.6 DRAINING AND FILLING, GEARBOX



To prevent skin injury, avoid unnecessary contact with the drained oil.

#### Gearbox ZF 16S-181/221

##### Draining the gearbox

1. Position the vehicle on a level surface.
2. Drain the gearbox at operating temperature.
3. Remove drain plugs B, C and D and the level check/filler plug (A) and drain the oil.

##### Filling the gearbox

1. Clean drain plugs (B), (C) and (D) and tighten them to the specified torque. See "Technical data".
2. Fill the oil through the level check/filling opening (A) until the oil reaches the rim of the filling opening.
3. Fit the level check/filler plug (A), tightening it to the specified torque. See "Technical data".

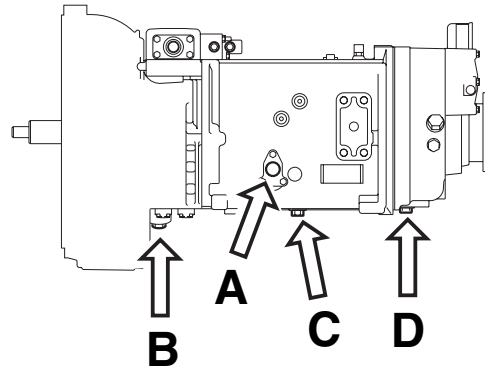

M3023

## EXPLANATORY NOTES ON THE MAINTENANCE ACTIVITIES

95XF series

Draining and filling

### Gearbox ZF 16S-181/221 with integrated retarder

#### Draining the gearbox

1. Before draining take a short test drive. Do **not** activate the intarder during the test drive.
2. Position the vehicle on a level surface.
3. Drain the gearbox at operating temperature.
4. Remove the drain plugs (1) and (2) and the level check/filler plug (4) and drain the oil.
5. Replace the oil filter (3) and tighten the attachment bolt of the oil filter to the specified tightening torque. See "Technical data".

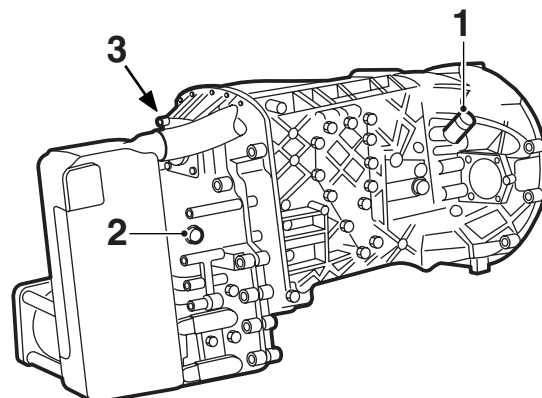

V300261

#### Filling the gearbox

1. Clean the drain plugs (1) and (2) and tighten them to the specified torque. See "Technical data".
2. Fill the oil through level check/filler opening (4) until the oil reaches the rim of the filling opening.
3. Fit level check/filler plug (4), tightening it to the specified torque, see "Technical data".
4. After filling take a short test drive. Do **not** activate the intarder during the test drive.
5. Check the oil level after taking the test drive. The oil level must reach the rim of the level check/filling opening (4).
6. Fit level check/filler plug (4), tightening it to the specified torque, see "Technical data".

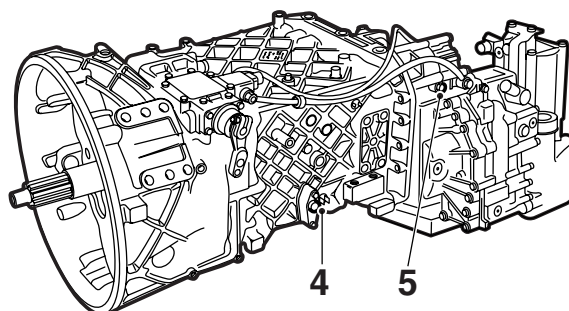

V300260

5

## EXPLANATORY NOTES ON THE MAINTENANCE ACTIVITIES

Draining and filling

95XF series

### 5.7 DRAINING AND FILLING, RETARDER



To prevent skin injury, avoid unnecessary contact with the drained oil.

#### VOITH 133-2

##### Draining the retarder

1. Drain off the oil when the retarder is at operating temperature.
2. Position the vehicle on a level surface.
3. Pressurise the air brake system (cut-out pressure of pressure regulator).
4. Fully activate the retarder and switch off after 5 seconds.  
Repeat this operation twice.
5. Remove the retarder oil drain plug (3) and drain off the oil.
6. Remove the butterfly valve drain plug (4) and drain the leak-off oil.
7. Fit the drain plugs (3) and (4) with new sealing rings and tighten them to the specified tightening torque. See "Technical data".

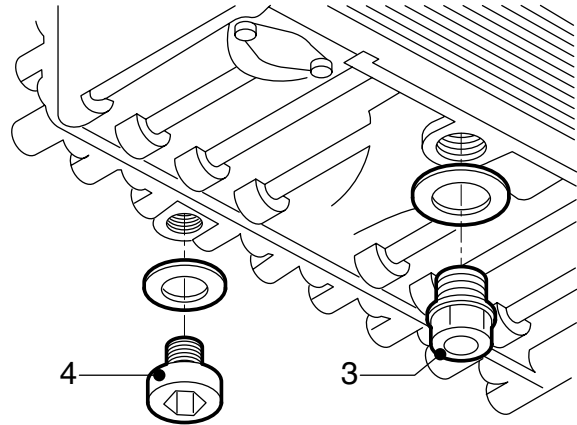

V300102

##### Filling the retarder

1. Fill the retarder with the prescribed amount of oil, either through the dipstick bore hole (1) or through the filler plug (2).  
If you use the filler plug (2), top up the oil slowly to prevent leaks via the vent opening.
2. Then tighten the filler plug, with new sealing ring in place, to the specified torque. See "Technical data".
3. Then check the oil level. See "Inspection and adjustment".

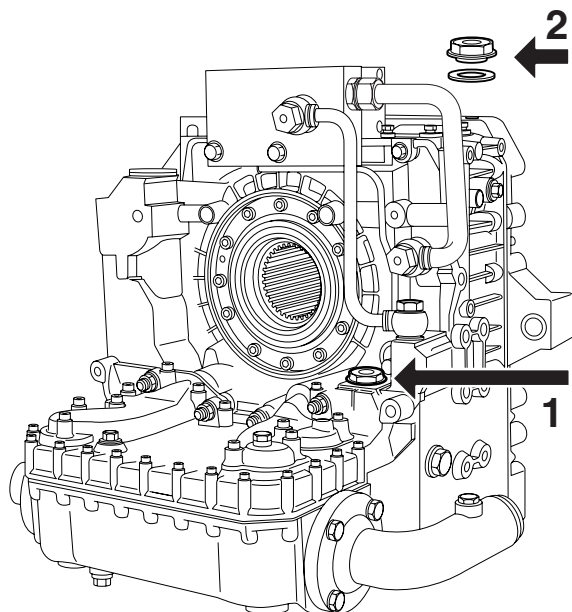

V300191

## EXPLANATORY NOTES ON THE MAINTENANCE ACTIVITIES

95XF series

Draining and filling

### 5.8 FILLING THE GREASE SUPPLY OF THE AUTOMATIC LUBRICATION SYSTEM

1. Remove the dust cover from the filler coupling (1).
2. Connect the filler line to the filler coupling. Ensure that the filler line is completely filled with grease so that no air bubbles can get into the system.
3. Fill the reservoir to the specified maximum level.

**Note:**

When filling the reservoir, the air above the follower piston will escape. This air will flow downward through an opening in the piston tube and escape from the pump through the right-angled coupling. A small amount of grease will usually escape from this coupling during bleeding.

4. Connect the filler line to the filler coupling.

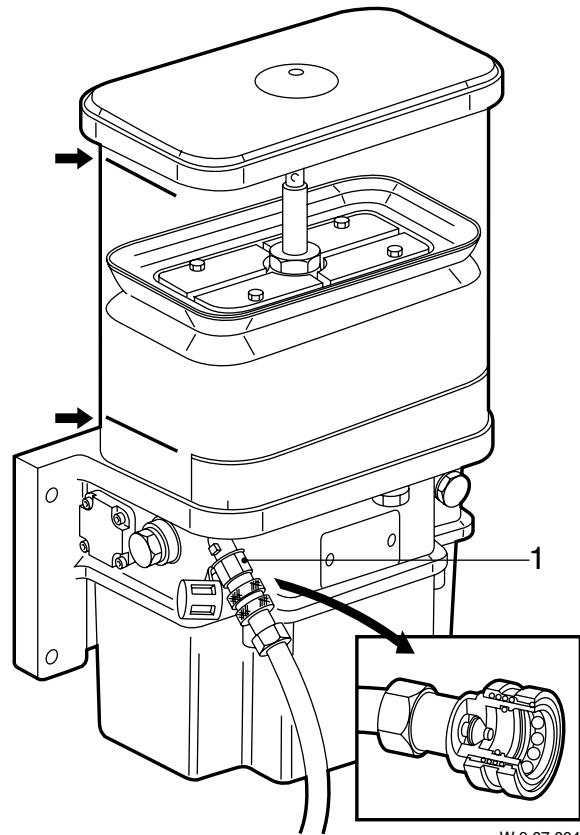

5

## **EXPLANATORY NOTES ON THE MAINTENANCE ACTIVITIES**

---

Draining and filling

**95XF** series

**5**

## EXPLANATORY NOTES ON THE MAINTENANCE ACTIVITIES

95XF series

Cleaning

### 6. CLEANING

#### 6.1 CLEANING THE INTERIOR FILTER ELEMENT

1. Remove the filter (2), see chapter "Removal and installation".
2. The filter can be cleaned by tapping off the dirt which has accumulated at the front off the filter surface. In case of excessive fouling or damage, the filter should be replaced.

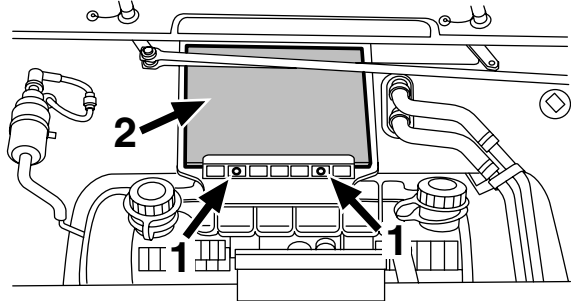

K100355

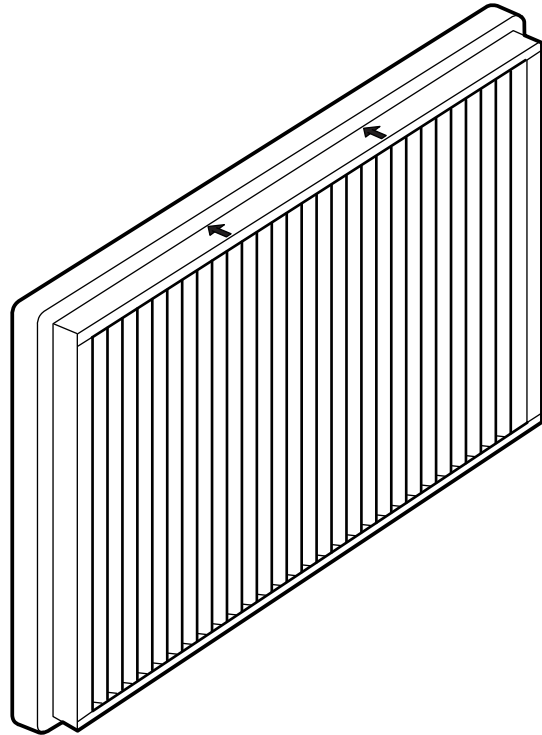

K100386

5

## EXPLANATORY NOTES ON THE MAINTENANCE ACTIVITIES

Cleaning

95XF series

### 6.2 CLEANING THE BATTERY TERMINALS



**Avoid sparks and open flames in the vicinity of batteries. Battery acid is an aggressive fluid.**

**In the event of contact with the skin: rinse the skin with plenty of water for a sustained period. If redness or pain persists, consult a doctor. Remove any clothing affected and rinse with water.**

**In the event of contact with the eyes: rinse with plenty of water for at least 15 minutes and see a doctor.**

**If swallowed: do NOT induce vomiting. Rinse the mouth, drink two glasses of water and see a doctor.**

**In the event of inhalation: get some fresh air, rest and consult a doctor.**

5

1. Disconnect the earth lead from the battery terminal.
2. Disconnect the positive lead from the battery terminal.
3. Clean the battery terminals, battery cables and the top side of the battery (oxide and dirt will discharge the battery).
4. If the top side of the battery is contaminated with acid, it should be rinsed with water.
5. Grease the battery terminals with petroleum jelly.
6. Check the earth lead connection to the chassis and grease the connection with petroleum jelly.
7. Fit the positive lead to the battery terminal.
8. Fit the earth lead to the battery terminal.
9. Check the routing and attachment of the battery cables.

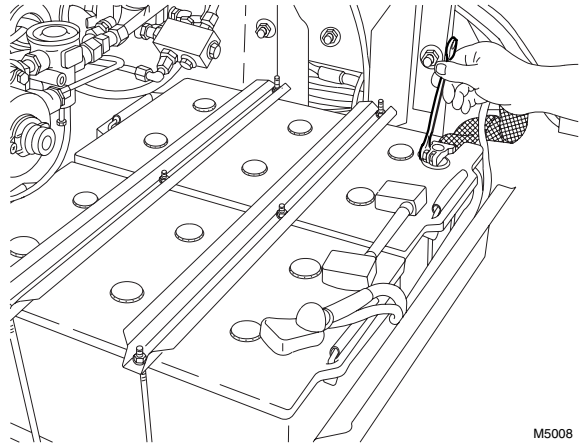

M5008



## EXPLANATORY NOTES ON THE MAINTENANCE ACTIVITIES

95XF series

Cleaning

### 6.3 CLEANING THE AIR FILTER ELEMENT



**Inhalation of dust can seriously damage your health. Take the necessary precautions, such as wearing goggles or a facemask.**

1. Remove the air filter element. See "Removal and installation".
2. Check the air filter element for damage. If the air filter element or its seals are damaged, the air filter element must be replaced.
3. Knock out the air filter element.
4. Blow the air filter element clean from the inside using compressed air. Maximum pressure approx. 1.5 bar.
5. Fit the air filter element. See "Removal and installation".
6. Reset the air filter indicator, if fitted, by pressing the button on the upper side of the indicator.

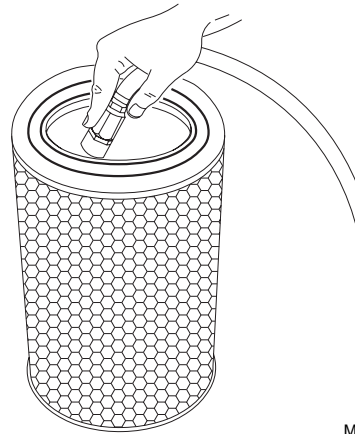

M2009

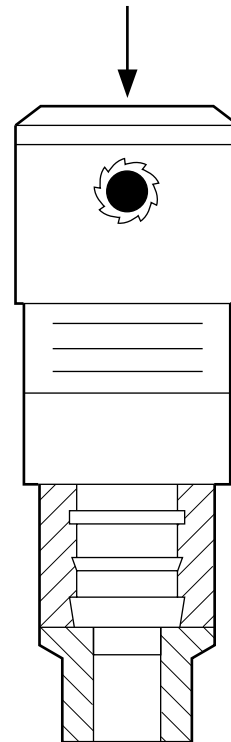

M200729

5

## EXPLANATORY NOTES ON THE MAINTENANCE ACTIVITIES

Cleaning

95XF series

### 6.4 CLEANING THE RADIATOR AND INTERCOOLER



**Inhalation of dust can seriously damage your health. Take the necessary precautions, such as wearing goggles or a facemask.**

#### Cleaning the protective screen

1. Remove the lower grille.
2. Unscrew the protective screen attachment bolts.
3. Remove the protective screen.
4. Clean the protective screen with a hard brush and blow-clean with compressed air.

#### Cleaning the radiator/intercooler element

##### Note:

With the aid of a simple tool, the radiator and the intercooler can be blow-cleaned. This tool can be made in your own workshop. It cannot be obtained from DAF.

##### Key to drawing:

1. Solder up
2. Solder
3. Quick-release coupling for air hose
4. Steel pipe, Ø 10 mm
5. 6 x Ø 1.5 mm, with a centre-to-centre distance between the holes of 7 mm, drilled on one side.

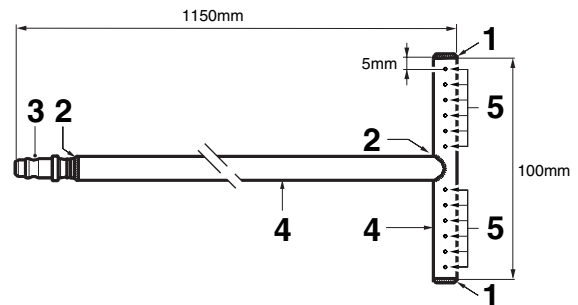

M2108

## EXPLANATORY NOTES ON THE MAINTENANCE ACTIVITIES

95XF series

Cleaning

1. Insert radiator cleaner (4) between intercooler (1) and radiator (2), from the bottom upwards, with the air holes facing the intercooler (1).
2. Apply air pressure to the radiator cleaner (4) and continue blow-cleaning the intercooler (1) until no more dirt comes out.

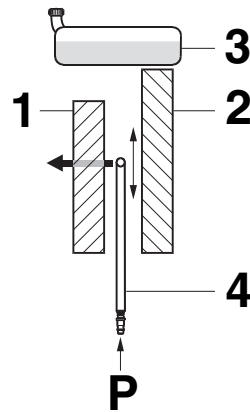

3. Turn the radiator cleaner over, turning the holes towards the radiator (2), and blow-clean the radiator (2).

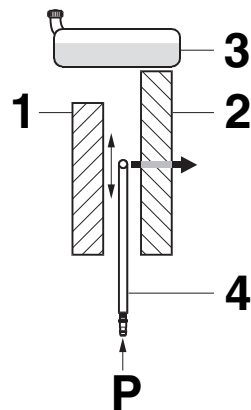

### 6.5 CLEANING THE FUEL COARSE FILTER

1. Remove the fuel coarse filter. See "Removal and installation".
2. Rinse the coarse filter with clean diesel fuel.
3. Blow-clean the coarse filter with compressed air, maximum pressure approx. 1 bar.

## EXPLANATORY NOTES ON THE MAINTENANCE ACTIVITIES

Cleaning

95XF series

### 6.6 CLEANING THE VEHICLE

**Note:**

Before cleaning the vehicle, check the engine, axles, gearbox, etc. for evidence of leakage. Having cleaned the vehicle, it will no longer be possible to check for leaks during the maintenance activities.

- Make sure that doors, windows and roof hatch are securely closed during cleaning.
- When cleaning the universal joint on the steering box, the spider seals may be forced open by the high-pressure jet of water, so that the grease behind them is flushed away. As a result, the spider may get stuck, so that the steering will “jam”.
- A bleed screw is fitted to the power steering fluid reservoir of the steering gear. Water may enter the power steering reservoir via the vent, which will cause damage to the steering gear.
- When cleaning the radiator/intercooler element, be careful not to damage the fins.
- Do not direct the high-pressure cleaner jet too long at the air-conditioning system condenser. As a result of the high temperature, the pressure in the system will rise too high, which may cause damage to the system.
- Make sure that no water can enter the differential and gearbox via the vents.

5

## EXPLANATORY NOTES ON THE MAINTENANCE ACTIVITIES

95XF series

Cleaning

- Make sure that no water can enter via the reservoir vents of clutch, brakes, trailing axle, etc.
- The engine and engine compartment can be cleaned with a high-pressure cleaner. Make sure in this case not to spray directly onto seals, electrical components, such as the starting motor, alternator, etc.
- When cleaning UPEC engines with a high-pressure cleaner, do not aim the jet directly at the pump units. Water could penetrate into the protective covers via the vent holes. This could result in faults in the electrical connections of the pump units.
- If an engine encapsulation is present, the encapsulation panels must be thoroughly cleaned after each inspection interval in view of the risk of fire if the inside of the panels should be dirty.
- Do not direct the jet of water at electrical connections such as connectors, cable plugs of the vehicle lighting system, etc.
- Make sure that during cleaning the vehicle no water enters into the air-intake system through the air intake of the flexible seals of the inlet.
- Do not aim the jet of water directly at the gear-lever unit.
- Do not point the high-pressure cleaning jet directly at the driving shaft seals, such as the seals of the spider, intermediate bearing and sliding joint.
- When the vehicle has been cleaned, it must be lubricated again with a grease gun or via the automatic lubrication system. This is important because it prevents the penetration of moisture and dirt at the various pivots.

## **EXPLANATORY NOTES ON THE MAINTENANCE ACTIVITIES**

---

Cleaning

**95XF** series

**5**

## EXPLANATORY NOTES ON THE MAINTENANCE ACTIVITIES

95XF series

Lubrication

### 7. LUBRICATION

#### 7.1 LUBRICATE ACCORDING TO LUBRICATION SCHEDULE

**Note:**

If the vehicle is equipped with a central lubrication system, all lubricating points are lubricated automatically with the exception of the propeller shaft.

# EXPLANATORY NOTES ON THE MAINTENANCE ACTIVITIES

## Lubrication

95XF series

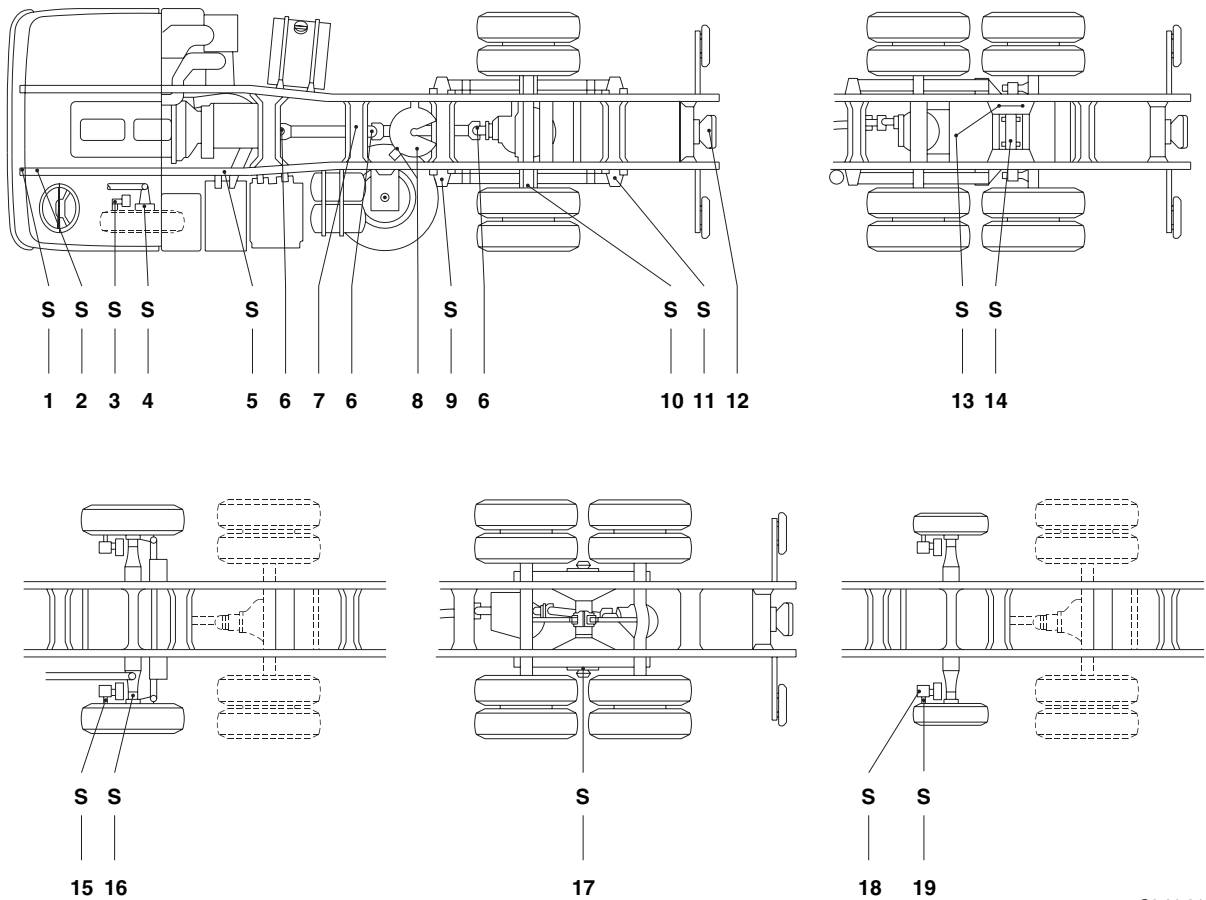

S = SYMMETRIC

1. Cab hinge pins
2. Shackle pins, front axle
3. Brake camshafts, front axle
4. King pins, front axle
5. Spring shackles, front axle
6. Universal joint
7. Centre bearing
8. Fifth wheel
9. Shackle pins, rear axle
10. Brake camshafts, rear axle
11. Spring shackles, rear axle
12. Drawn vehicle coupling
13. Pivoting points of trailer axle load transfer device (leaf sprung)
14. Pivoting points of trailing axle (leaf sprung)
15. Brake camshafts, leading rear axle
16. King pins, leading rear axle
17. Central axle of tandem axle unit
18. Automatic brake adjusters, FTP leading rear axle
19. Brake camshafts, FTP leading rear axle

C9 00 345



## EXPLANATORY NOTES ON THE MAINTENANCE ACTIVITIES

95XF series

Lubrication

### Lubricating the propeller shaft

1. Lubricate the universal joints of the propeller shaft, until grease comes out.
2. The maximum lubricating pressure should not exceed 15 bar.

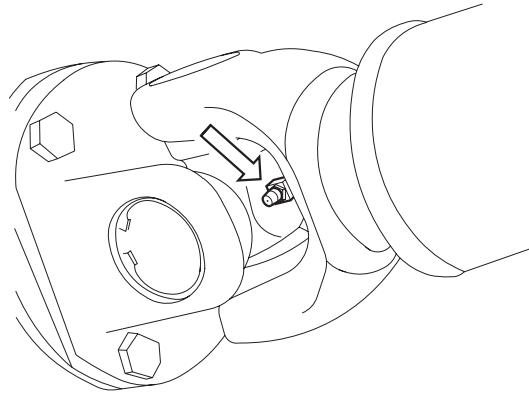

M9030

### Lubrication of king pins

1. To make sure that the grease can penetrate adequately, the king pins should be lubricated in unloaded condition. The front axle should therefore be completely jacked up.
2. Lubricate the king pins until grease comes out.

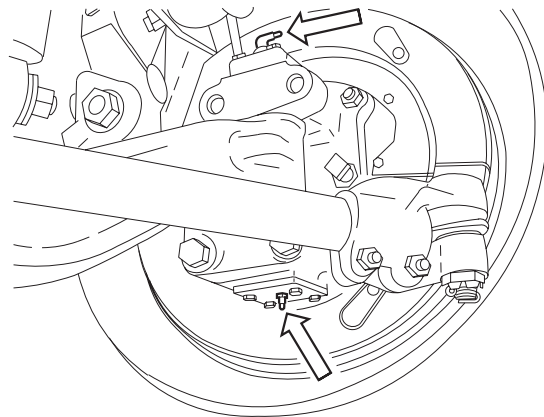

M9025

### Fifth wheel

1. Clean the surface of the fifth wheel and apply clean grease.

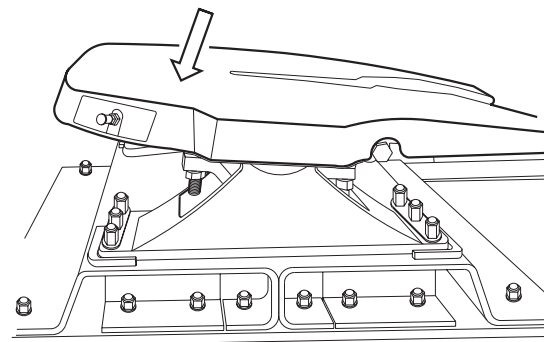

M9024

## EXPLANATORY NOTES ON THE MAINTENANCE ACTIVITIES

Lubrication

95XF series

### Automatic brake adjusters and brake camshafts, FTP leading rear axle

1. Lubricate the automatic brake adjusters and brake camshafts using the lubricating nipples.

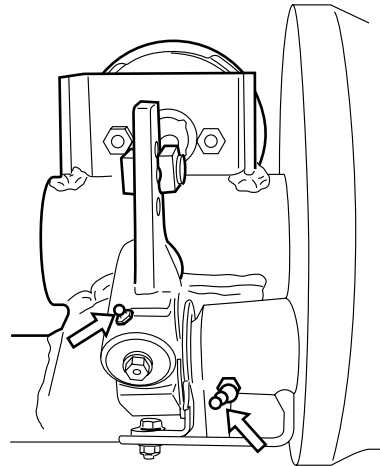

C9 00 346



